

REVIEWER NOTES

- 1: BRIDGE IS CURRENTLY CLOSED, TRAFFIC CONTROL WILL BE THE CURRENT TOWN MARKED DETOUR
- 2: UTILITY RELOCATION IS ANTICIPATED TO BE NECESSARY.
- 3:

STATE OF VERMONT AGENCY OF TRANSPORTATION

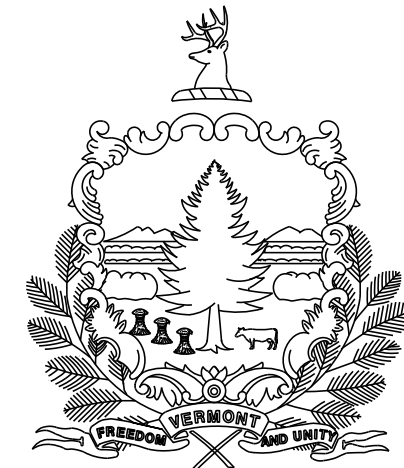

PROPOSED IMPROVEMENT BRIDGE PROJECT

TOWN OF ENOSBURG
COUNTY OF FRANKLIN

ROUTE NO: TOWN HIGHWAY 4 (BAKERSFIELD RD.) BRIDGE NO : 50

PROJECT LOCATION: APPROXIMATELY 200 FEET FROM THE INTERSECTION OF TH-4E (BAKERSFIELD RD) AND TH-4 (HORSESHOE CIRCLE).

PROJECT DESCRIPTION: REMOVAL AND REPLACEMENT OF EXISTING BRIDGE.

LENGTH OF STRUCTURE: 90.00 FEET
 LENGTH OF ROADWAY: 197.50 FEET
 LENGTH OF PROJECT: 287.50 FEET

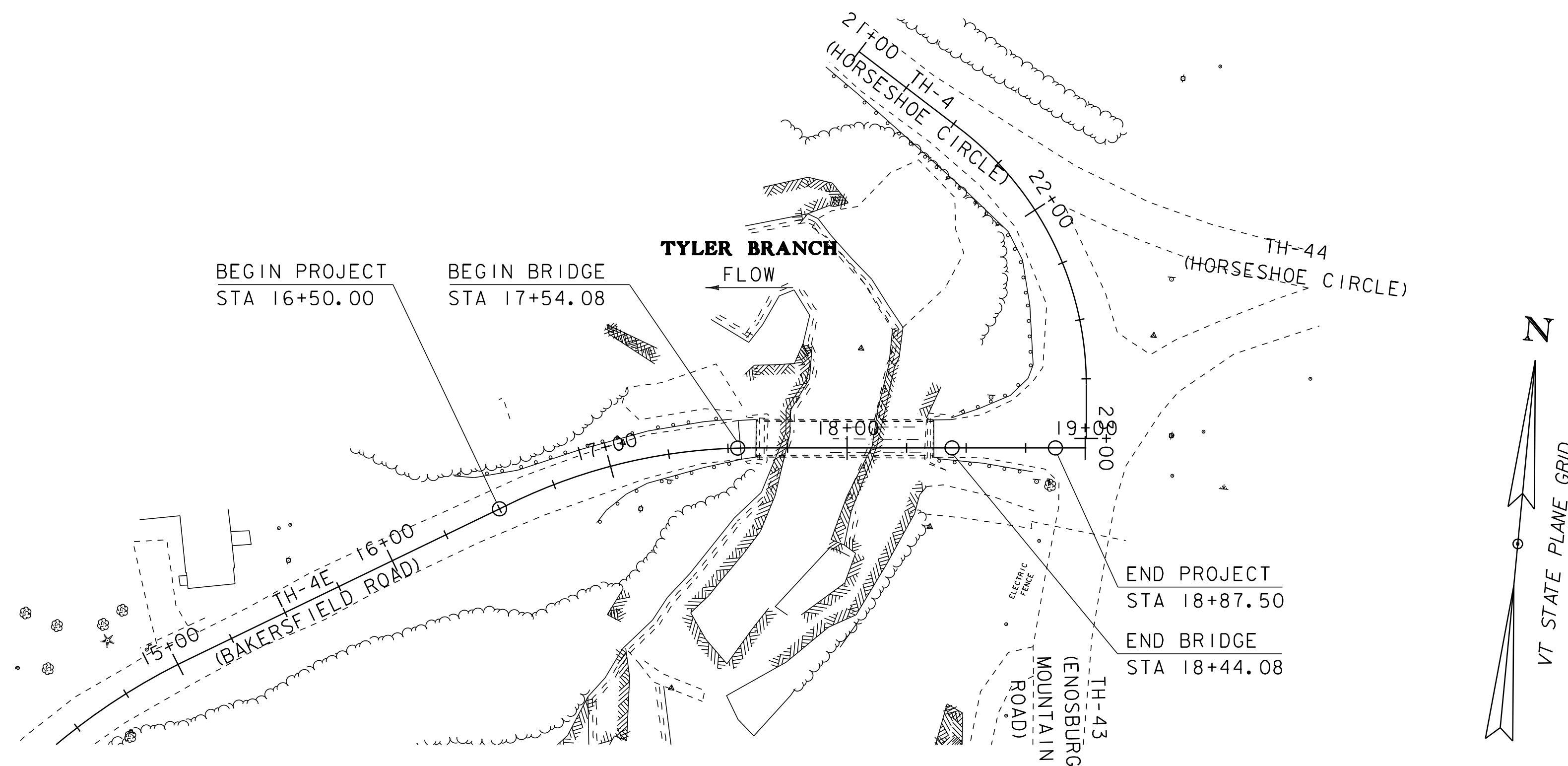
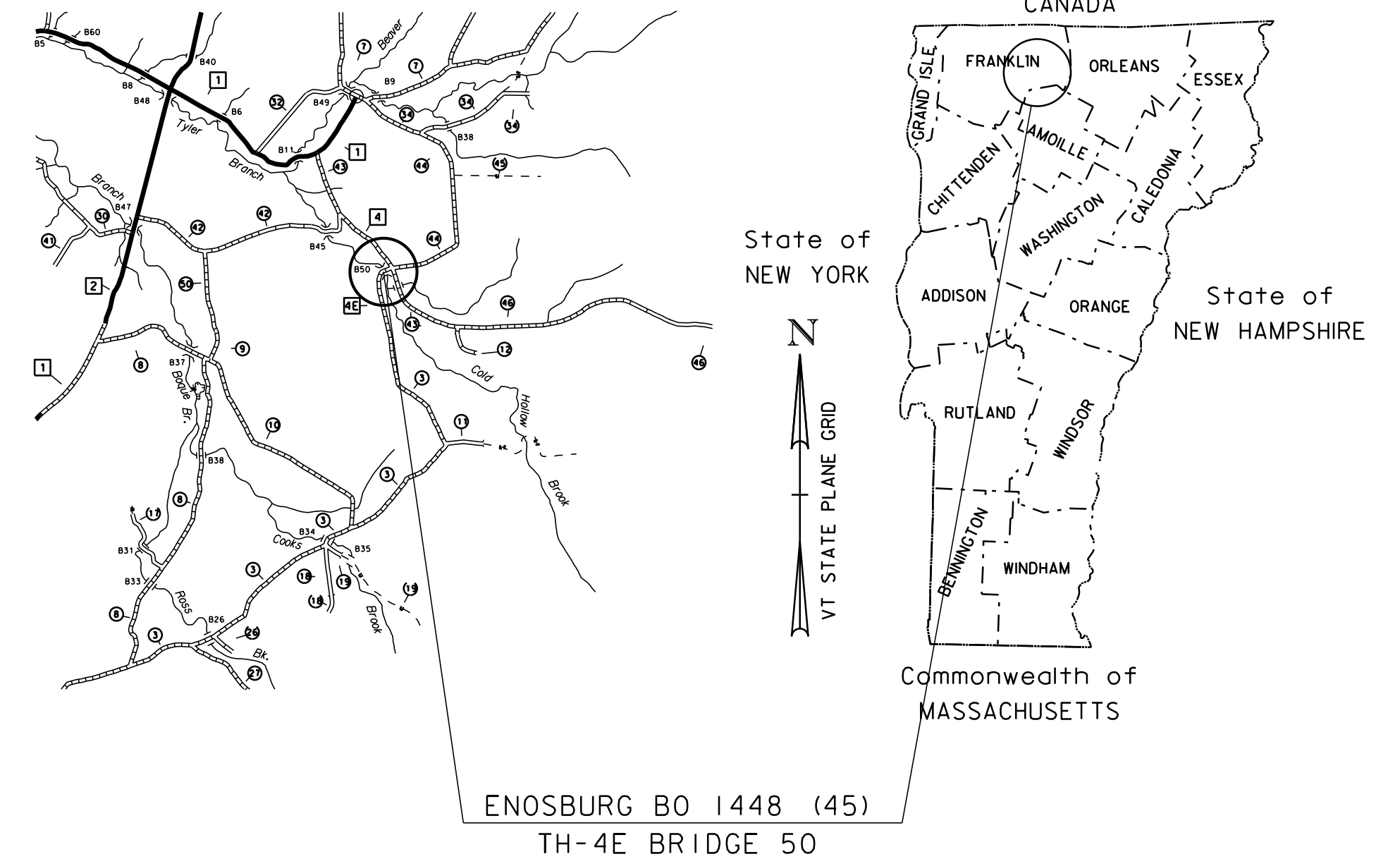

CONSTRUCTION IS TO BE CARRIED ON IN ACCORDANCE WITH THESE PLANS AND THE STANDARD SPECIFICATIONS FOR CONSTRUCTION DATED 2018, AS APPROVED BY THE FEDERAL HIGHWAY ADMINISTRATION ON APRIL 13, 2018 FOR USE ON THIS PROJECT, INCLUDING ALL SUBSEQUENT REVISIONS AND SUCH REVISED SPECIFICATIONS AND SPECIAL PROVISIONS AS ARE INCORPORATED IN THESE PLANS.

QUALITY ASSURANCE PROGRAM : LEVEL 2	
SURVEYED BY :	R. GILMAN
SURVEYED DATE :	11/05/2019
DATUM	
VERTICAL	NAVD88
HORIZONTAL	NAD83 (2011)

SCALE 1" = 40' - 0"

HIGHWAY DIVISION, CHIEF ENGINEER
APPROVED _____ DATE _____
PROJECT MANAGER : R. S. YOUNG
PROJECT NAME : ENOSBURG
PROJECT NUMBER : B0 1448 (45)
SHEET 1 OF 20 SHEETS

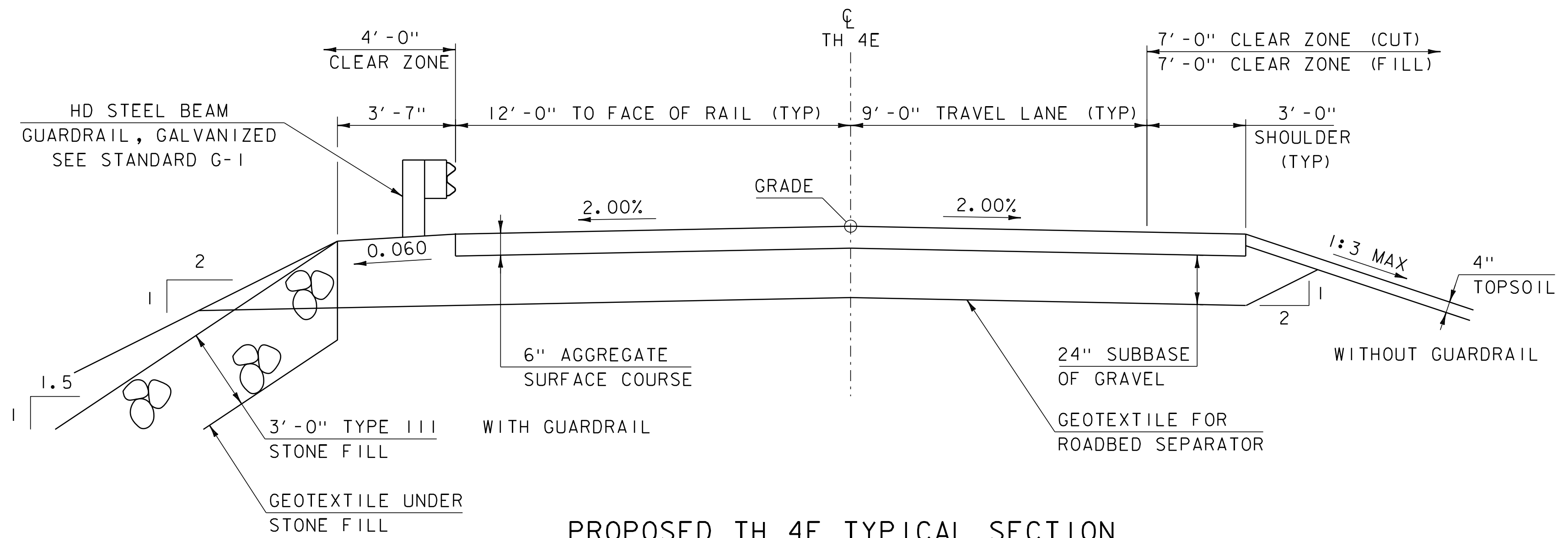
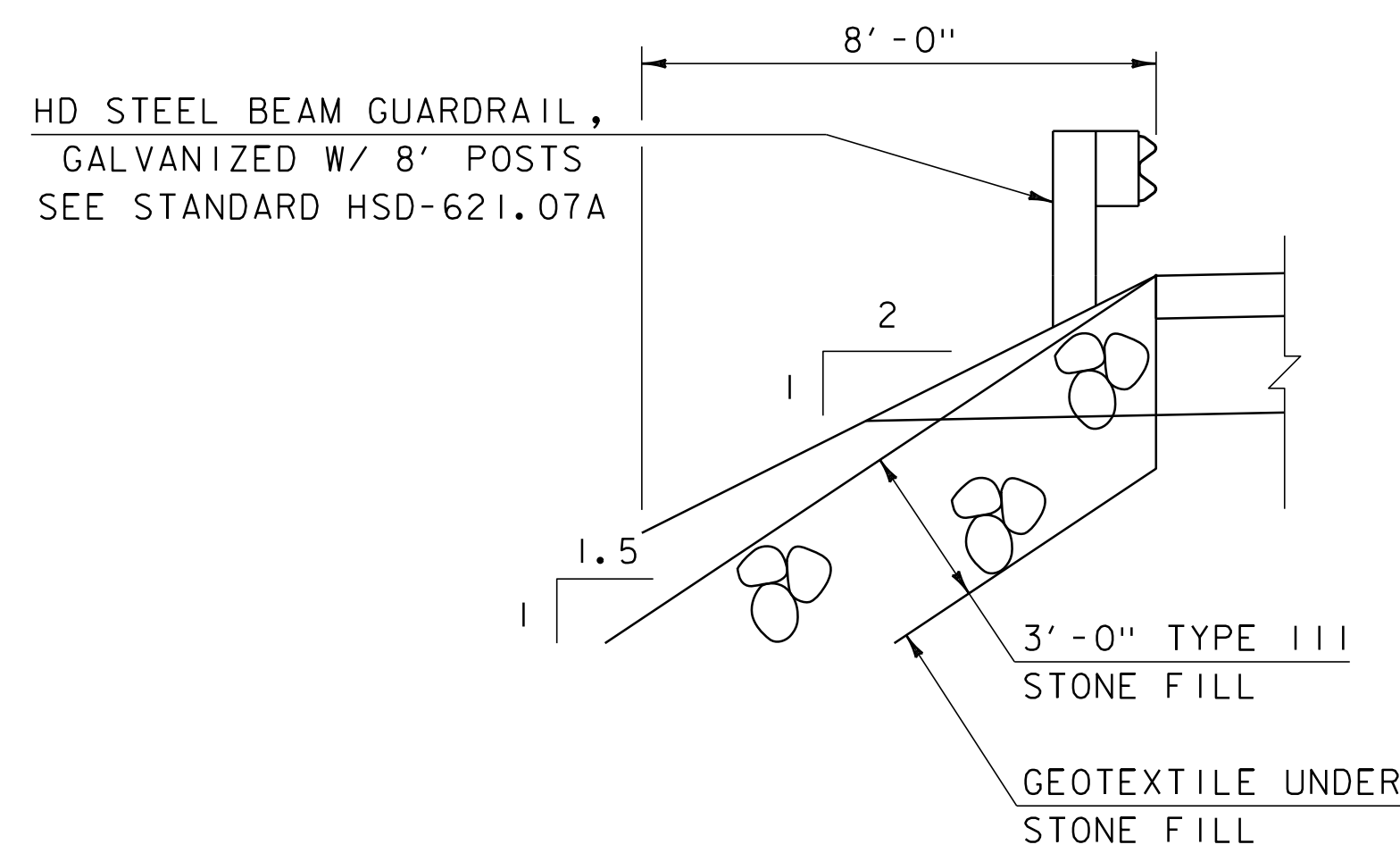

PROPOSED TH 4E TYPICAL SECTION
SCALE 3/8" = 1'-0"

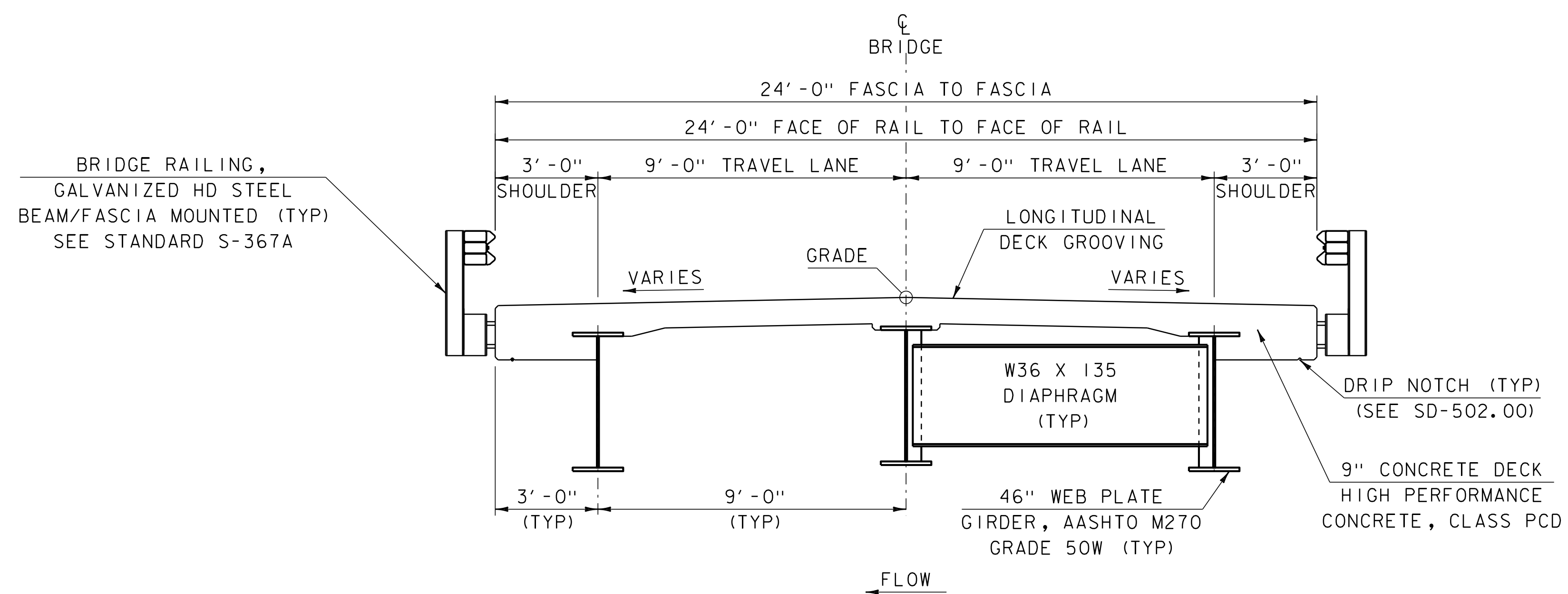

PROPOSED BRIDGE TYPICAL SECTION
SCALE 3/8" = 1'-0"

MATERIAL TOLERANCES
(IF USED ON PROJECT)

SURFACE	
- PAVEMENT (TOTAL THICKNESS)	+/- 1/4"
- AGGREGATE SURFACE COURSE	+/- 1/2"
SUBBASE	+/- 1"
SAND BORROW	+/- 1"

PROJECT NAME: ENOSBURG
PROJECT NUMBER: BO 1448(45)

FILE NAME: I9J224/s19J224+yp.dgn
PROJECT LEADER: R.YOUNG
DESIGNED BY: D.PETERSON
TYPICAL SECTIONS

PLOT DATE: 06-JUL-2020
DRAWN BY: D.D.BEARD
CHECKED BY: J.LACROIX
SHEET 3 OF 20

GENERAL INFORMATION

SYMBOLGY LEGEND NOTE

THE SYMBOLGY ON THIS SHEET IS INTENDED TO COVER STANDARD CONVENTIONAL SYMBOLGY. THE SYMBOLGY IS USED FOR EXISTING & PROPOSED FEATURES WITH HEAVIER LINEWEIGHT, IN COMBINATION WITH PROJECT ANNOTATION, AS NOTED ON PROJECT PLAN SHEETS. THIS LEGEND SHEET COVERS THE BASICS. SYMBOLGY ON PLANS MAY VARY, PLAN ANNOTATIONS AND NOTES SHOULD BE USED TO CLARIFY AS NEEDED.

R.O.W. ABBREVIATIONS (CODES) & SYMBOLS

POINT CODE	DESCRIPTION
BF	BARRIER FENCE
CH	CHANNEL EASEMENT
CONST	CONSTRUCTION EASEMENT
CUL	CULVERT EASEMENT
D&C	DISCONNECT & CONNECT
DIT	DITCH EASEMENT
DR	DRAINAGE EASEMENT
DRIVE	DRIVEWAY EASEMENT
EC	EROSION CONTROL
HWY	HIGHWAY EASEMENT
I&M	INSTALL & MAINTAIN EASEMENT
LAND	LANDSCAPE EASEMENT
PDF	PROJECT DEMARCATION FENCE
R&RES	REMOVE & RESET
R&REP	REMOVE & REPLACE
R.T.& I.	RIGHT, TITLE, AND INTEREST
SR	SLOPE RIGHT
UE	UTILITY EASEMENT
(P)	PERMANENT EASEMENT
(T)	TEMPORARY EASEMENT
■	BNDNS BOUND SET
□	BNDNS BOUND TO BE SET
⊙	IPNF IRON PIN FOUND
●	IPNS IRON PIN TO BE SET
⊠	CALC EXISTING ROW POINT
○	PROW PROPOSED ROW POINT
[LENGTH]	LENGTH CARRIED ON NEXT SHEET

COMMON TOPOGRAPHIC POINT SYMBOLS

POINT CODE	DESCRIPTION
⊕	APL BOUND APPARENT LOCATION
□	BM BENCHMARK
⊞	BND BOUND
⊞	CB CATCH BASIN
⊞	COMB COMBINATION POLE
⊞	DITHR DROP INLET THROATED DNC
⊞	EL ELECTRIC POWER POLE
⊞	FPOLE FLAGPOLE
○	GASFIL GAS FILLER
○	GP GUIDE POST
×	GSO GAS SHUT OFF
○	GUY GUY POLE
○	GUYW GUY WIRE
×	GV GATE VALVE
⊞	H TREE HARDWOOD
△	HCTRL CONTROL HORIZONTAL
△	HVCTRL CONTROL HORIZ. & VERTICAL
◇	HYD HYDRANT
○	IP IRON PIN
●	IPIPE IRON PIPE
⊞	LI LIGHT - STREET OR YARD
⊞	MB MAILBOX
○	MH MANHOLE (MH)
⊞	MM MILE MARKER
⊞	PM PARKING METER
⊞	PMK PROJECT MARKER
○	POST POST STONE/WOOD
⊞	RRSIG RAILROAD SIGNAL
⊞	RRSL RAILROAD SWITCH LEVER
⊞	S TREE SOFTWOOD
⊞	SAT SATELLITE DISH
⊞	SHRUB SHRUB
⊞	SIGN SIGN
⊞	STUMP STUMP
⊞	TEL TELEPHONE POLE
○	TIE TIE
⊞	TSIGN SIGN W/DOUBLE POST
⊞	VCTRL CONTROL VERTICAL
○	WELL WELL
×	WSO WATER SHUT OFF

THESE ARE COMMON VAOT SURVEY POINT SYMBOLS FOR EXISTING FEATURES, ALSO USED FOR PROPOSED FEATURES WITH HEAVIER LINEWEIGHT, IN COMBINATION WITH PROPOSED ANNOTATION.

PROPOSED GEOMETRY CODES

CODE	DESCRIPTION
PC	POINT OF CURVATURE
PI	POINT OF INTERSECTION
CC	CENTER OF CURVE
PT	POINT OF TANGENCY
PCC	POINT OF COMPOUND CURVE
PRC	POINT OF REVERSE CURVE
POB	POINT OF BEGINNING
POE	POINT OF ENDING
STA	STATION PREFIX
AH	AHEAD STATION SUFFIX
BK	BACK STATION SUFFIX
D	CURVE DEGREE OF (100FT)
R	CURVE RADIUS OF
T	CURVE TANGENT LENGTH
L	CURVE LENGTH OF
E	CURVE EXTERNAL DISTANCE
CB	CHORD BEARING

UTILITY SYMBOLGY

UNDERGROUND UTILITIES

— UGU —	UTILITY (GENERIC-UNKNOWN)
— UT —	TELEPHONE
— UE —	ELECTRIC
— UC —	CABLE (TV)
— UEC —	ELECTRIC+CABLE
— UET —	ELECTRIC+TELEPHONE
— UCT —	CABLE+TELEPHONE
— UECT —	ELECTRIC+CABLE+TELEPHONE
— G —	GAS LINE
— W —	WATER LINE
— S —	SANITARY SEWER (SEPTIC)

ABOVE GROUND UTILITIES (AERIAL)

— AGU —	UTILITY (GENERIC-UNKNOWN)
— T —	TELEPHONE
— E —	ELECTRIC
— C —	CABLE (TV)
— EC —	ELECTRIC+CABLE
— ET —	ELECTRIC+TELEPHONE
— AER E&T —	ELECTRIC+TELEPHONE
— CT —	CABLE+TELEPHONE
— ECT —	ELECTRIC+CABLE+TELEPHONE
—	UTILITY POLE GUY WIRE

PROJECT CONSTRUCTION SYMBOLGY

PROJECT DESIGN & LAYOUT SYMBOLGY

— CZ —	CLEAR ZONE
—	PLAN LAYOUT MATCHLINE

PROJECT CONSTRUCTION FEATURES

—	TOP OF CUT SLOPE
—	TOE OF FILL SLOPE
—	STONE FILL
—	BOTTOM OF DITCH
—	CULVERT PROPOSED
—	STRUCTURE SUBSURFACE
PDF	PROJECT DEMARCATION FENCE
BF	BARRIER FENCE
—	TREE PROTECTION ZONE (TPZ)
—	STRIPING LINE REMOVAL
—	SHEET PILES

CONVENTIONAL BOUNDARY SYMBOLGY

BOUNDARY LINES

— TOWN LINE —	TOWN BOUNDARY LINE
— COUNTY LINE —	COUNTY BOUNDARY LINE
— STATE LINE —	STATE BOUNDARY LINE
—	PROPOSED STATE R.O.W. (LIMITED ACCESS)
—	PROPOSED STATE R.O.W.
—	STATE ROW (LIMITED ACCESS)
—	STATE ROW
—	TOWN ROW
—	PERMANENT EASEMENT LINE (P)
—	TEMPORARY EASEMENT LINE (T)
—	SURVEY LINE
P	PROPERTY LINE (P/L)
L	SLOPE RIGHTS
SR	6F PROPERTY BOUNDARY
6f	4F PROPERTY BOUNDARY
4f	HAZARDOUS WASTE
HAZ	

EPSC LAYOUT PLAN SYMBOLGY

EPSC MEASURES

—	FILTER CURTAIN
—	SILT FENCE
—	SILT FENCE WOVEN WIRE
—	CHECK DAM
—	DISTURBED AREAS REQUIRING RE-VEGETATION
—	EROSION MATTING

SEE EPSC DETAIL SHEETS FOR ADDITIONAL SYMBOLGY

ENVIRONMENTAL RESOURCES

—	WETLAND BOUNDARY
—	RIPARIAN BUFFER ZONE
—	WETLAND BUFFER ZONE
—	SOIL TYPE BOUNDARY
— T&E —	THREATENED & ENDANGERED SPECIES
— HAZ —	HAZARDOUS WASTE AREA
— AG —	AGRICULTURAL LAND
— HABITAT —	FISH & WILDLIFE HABITAT
— FLOOD PLAIN —	FLOOD PLAIN
— OHW —	ORDINARY HIGH WATER (OHW)
—	STORM WATER
—	USDA FOREST SERVICE LANDS
—	WILDLIFE HABITAT SUIT/CONN

ARCHEOLOGICAL & HISTORIC

— ARCH —	ARCHEOLOGICAL BOUNDARY
— HISTORIC DIST —	HISTORIC DISTRICT BOUNDARY
— HISTORIC —	HISTORIC AREA
Ⓜ	HISTORIC STRUCTURE

CONVENTIONAL TOPOGRAPHIC SYMBOLGY

EXISTING FEATURES

—	ROAD EDGE PAVEMENT
—	ROAD EDGE GRAVEL
—	DRIVEWAY EDGE
—	DITCH
—	FOUNDATION
—	FENCE (EXISTING)
—	FENCE WOOD POST
—	FENCE STEEL POST
—	GARDEN
—	ROAD GUARDRAIL
—	RAILROAD TRACKS
—	CULVERT (EXISTING)
—	STONE WALL
—	WALL
—	WOOD LINE
—	BRUSH LINE
—	HEDGE
—	BODY OF WATER EDGE
—	LEDGE EXPOSED

PROJECT NAME:	ENOSBURG
PROJECT NUMBER:	BO 1448(45)
FILE NAME:	I9J224/sI9J224forms.dgn
PROJECT LEADER:	R.S.YOUNG
DESIGNED BY:	-----
LEGEND SHEET	
PLOT DATE:	06-JUL-2020
DRAWN BY:	M.LONGSTREET
CHECKED BY:	-----
SHEET	4 OF 20

REMOVAL AND DISPOSAL OF GUARDRAIL

STA 16+38.90 - STA 17+62.25 LT
STA 16+87.20 - STA 17+62.25 RT
STA 18+36.25 - STA 18+73.65 LT
STA 18+36.25 - STA 18+78.00 RT

MANUFACTURED TERMINAL SECTION, FLARED

STA 16+32.55 - STA 16+82.15 LT
STA 16+46.80 - STA 17+00.00 RT

HD STEEL BEAM GUARDRAIL, GALVANIZED, W/ 8 FOOT POSTS

STA 16+82.15 - STA 17+29.66 LT

HD STEEL BEAM GUARDRAIL, GALVANIZED

STA 17+00.00 - STA 17+26.36 RT
STA 18+67.88 - STA 18+73.65 LT
STA 18+69.08 - STA 18+81.25 RT

APPROACH SECTION, GALVANIZED HD STEEL BEAM

STA 17+29.66 - STA 17+54.08 LT (8' POSTS)
STA 17+26.36 - STA 17+54.08 RT
STA 18+44.08 - STA 18+67.88 LT
STA 18+44.08 - STA 18+69.08 RT

BRIDGE RAILING, GALVANIZED HD STEEL BEAM/FASCIA MOUNTED

STA 17+54.08 - STA 18+44.08 LT/RT

ANCHOR FOR STEEL BEAM RAIL

STA 18+75.40 RT

STONE FILL, TYPE III
STA 18+28.70 - STA 18+78.60 LT

STONE FILL, TYPE III
STA 16+50.00 - STA 17+54.08 LT

REMOVE SIGNS

STA 17+23.35 RT
STA 18+60.50 LT
STA 18+79.60 RT (X5)

TRAFFIC SIGN, TYPE A

STA 18+78.40 RT

RESET SIGN

STA 18+78.40 RT (X4)

EXISTING CURVE 1
DELTA = 50°57'51"
D = 21°37'16"
R = 265.00'
T = 126.30'
L = 235.72'
E = 28.56'

APPROX. EXISTING TOWN R.O.W.
TH-4E (BAKERSFIELD ROAD)
MAILBOX #7 179
SATELLITE ANTENNA
FIELD DRIVE
GUY WIRE
HVCTRL
COMB

BEGIN PROJECT
STA 16+50.00

BEGIN APPROACH
STA 16+00.00

STONE FILL, TYPE III

PROPOSED CURVE 2
DELTA = 25°47'56"
D = 24°48'12"
R = 231.00'
T = 52.90'
L = 104.01'
E = 5.98'

STA 18+00.00 =
CHAN 54+50.00
Δ = 90°00'00" LT
BEGIN BRIDGE
STA 17+54.08

POE
STA 55+50.00

POB
STA 53+00.00
WELL

END BRIDGE
STA 18+44.08

END PROJECT
STA 18+87.50

TH-43 EXISTING CURVE 1
DELTA = 24°52'31"
D = 12°03'44"
R = 475.00'
T = 104.76'
L = 206.22'
E = 11.42'

EXISTING BRIDGE INFORMATION
BUILT 1918, REBUILT 1975
74' SINGLE SPAN ROLLED BEAM
CONCRETE CAST IN PLACE DECK

LAYOUT

SCALE 1" = 20'-0"
20 0 20

PROJECT NAME: ENOSBURG
PROJECT NUMBER: BO 1448(45)

FILE NAME: I9J224/s19J224border.dgn
PROJECT LEADER: R.YOUNG
DESIGNED BY: D.PETERSON
LAYOUT SHEET

PLOT DATE: 06-JUL-2020
DRAWN BY: D.D.BEARD
CHECKED BY: J.LACROIX
SHEET 5 OF 20

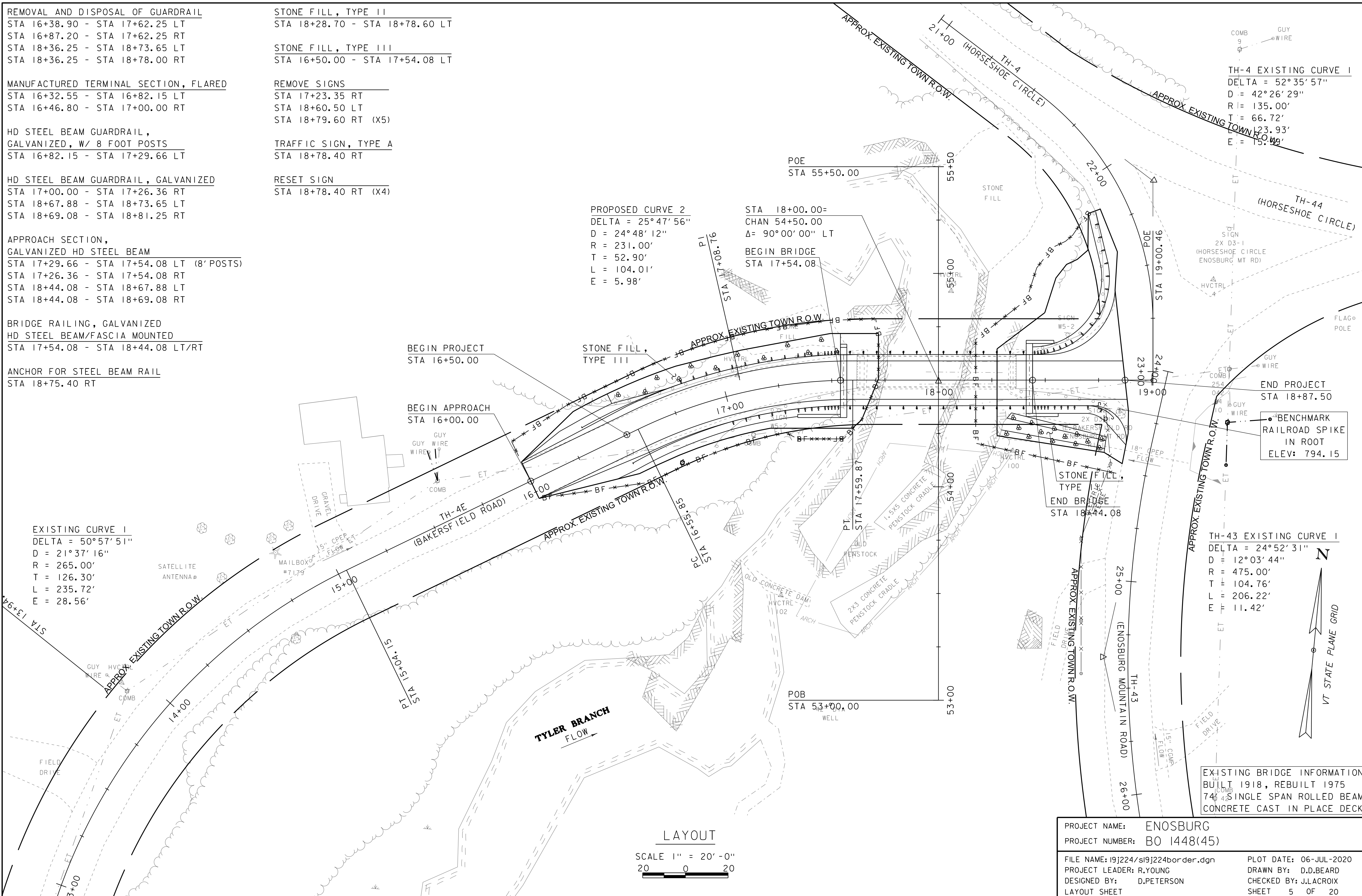

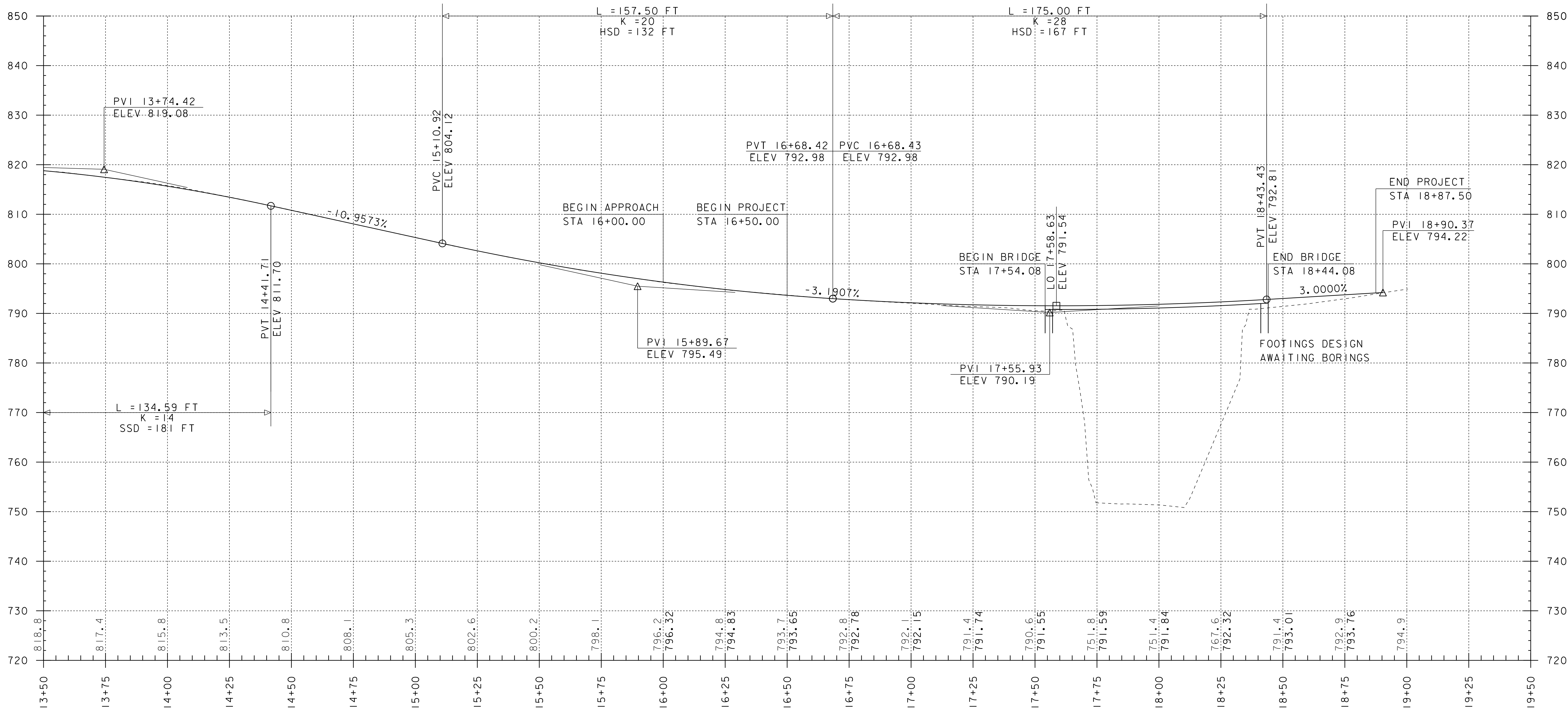

TH-4E (BAKERSFIELD ROAD) PROFILE

SCALE: HORIZONTAL 1"=20'-0"
 VERTICAL 1"=10'-0"

NOTE:
 GRADES SHOWN TO THE NEAREST TENTH ARE EXISTING GROUND ALONG CL
 GRADES SHOWN TO THE NEAREST HUNDREDTH ARE FINISH GRADE ALONG CL

PROJECT NAME:	ENOSBURG	FILE NAME:	I9J224/sI9J224profile.dgn	PLOT DATE:	06-JUL-2020
PROJECT NUMBER:	BO 1448(45)	PROJECT LEADER:	R.YOUNG	DRAWN BY:	D.D.BEARD
		DESIGNED BY:	D.PETERSON	CHECKED BY:	J.LACROIX
		PROFILE SHEET			SHEET 6 OF 20

SOIL CLASSIFICATION

AASHTO	
A1	Gravel and Sand
A3	Fine Sand
A2	Silty or Clayey Gravel and Sand
A4	Silty Soil - Low Compressibility
A5	Silty Soil - Highly Compressible
A6	Clayey Soil - Low Compressibility
A7	Clayey Soil - Highly Compressible

ROCK QUALITY DESIGNATION

R.O.D. (%)	ROCK DESCRIPTION
<25	Very Poor
25 to 50	Poor
51 to 75	Fair
76 to 90	Good
>90	Excellent

SHEAR STRENGTH

UNDRAINED SHEAR STRENGTH IN P.S.F.	CONSISTENCY
<250	Very Soft
250-500	Soft
500-1000	Med. Stiff
1000-2000	Stiff
2000-4000	Very Stiff
>4000	Hard

CORRELATION GUIDE OF "N" TO DENSITY/CONSISTENCY

DENSITY (GRANULAR SOILS)		CONSISTENCY (COHESIVE SOILS)	
N	DESCRIPTIVE TERM	N	DESCRIPTIVE TERM
<5	Very Loose	<2	Very Soft
5-10	Loose	2-4	Soft
11-24	Med. Dense	5-8	Med. Stiff
25-50	Dense	9-15	Stiff
>50	Very Dense	16-30	Very Stiff
		31-60	Hard
		>60	Very Hard

COMMONLY USED SYMBOLS

- ▼ Water Elevation
- ⊕ Standard Penetration Boring
- ⊗ Auger Boring
- ⊙ Rod Sounding
- ⊖ Sample
- N Standard Penetration Test
- Blow Count Per Foot For:
- 2" O.D. Sampler
- 1 3/8" I.D. Sampler
- Hammer Weight Of 140 Lbs.
- Hammer Fall Of 30"
- VS Field Vane Shear Test
- US Undisturbed Soil Sample
- B Blast
- DC Diamond Core
- MD Mud Drill
- WA Wash Ahead
- HSA Hollow Stem Auger
- AX Core Size 1 1/8"
- BX Core Size 1 3/8"
- NX Core Size 2 1/8"
- M Double Tube Core Barrel Used
- LL Liquid Limit
- PL Plastic Limit
- PI Plasticity Index
- NP Non Plastic
- w Moisture Content (Dry Wgt. Basis)
- D Dry
- M Moist
- MTW Moist To Wet
- W Wet
- Sat Saturated
- Bo Boulder
- Gr Gravel
- Sa Sand
- Si Silt
- Cl Clay
- HP Hardpan
- Le Ledge
- NLTD No Ledge To Depth
- CNPF Can Not Penetrate Further
- TLOB Top of Ledge Or Boulder
- NR No Recovery
- Rec. Recovery
- 1/2 Rec. Percent Recovery
- ROD Rock Quality Designation
- CBR California Bearing Ratio
- < Less Than
- > Greater Than
- R Refusal (N > 100)
- VTSPG NAD83 - See Note 7

COLOR			
blk	Black	pnk	Pink
bl	Blue	pu	Purple
brn	Brown	rd	Red
dk	Dark	tn	Tan
gr	Gray	wh	White
gn	Green	yel	Yellow
lt	Light	mltc	Multicolored
or	Orange		

BORING CHART

HOLE NO.	SURV. STATION	OFFSET	GROUND ELEV.	ELEV. TLOB	NORTHING	EASTING
B01	17+50	0.0			854668.78	1581191.86
B02	18+48	0.0			854678.27	1581288.98
R01	17+35	18.0LT			854682.56	1581172.55
R02	17+33	21.0RT			854644.15	1581179.71
R03	17+57	15.6LT			854684.79	1581195.94
R04	17+56	15.0RT			854654.16	1581198.87
R05	18+43	14.7LT			854692.57	1581282.59
R06	18+43	15.5RT			854662.28	1581285.49
R07	18+57	25.0LT			854704.00	1581295.02
R08	18+57	15.5RT			854663.57	1581298.93

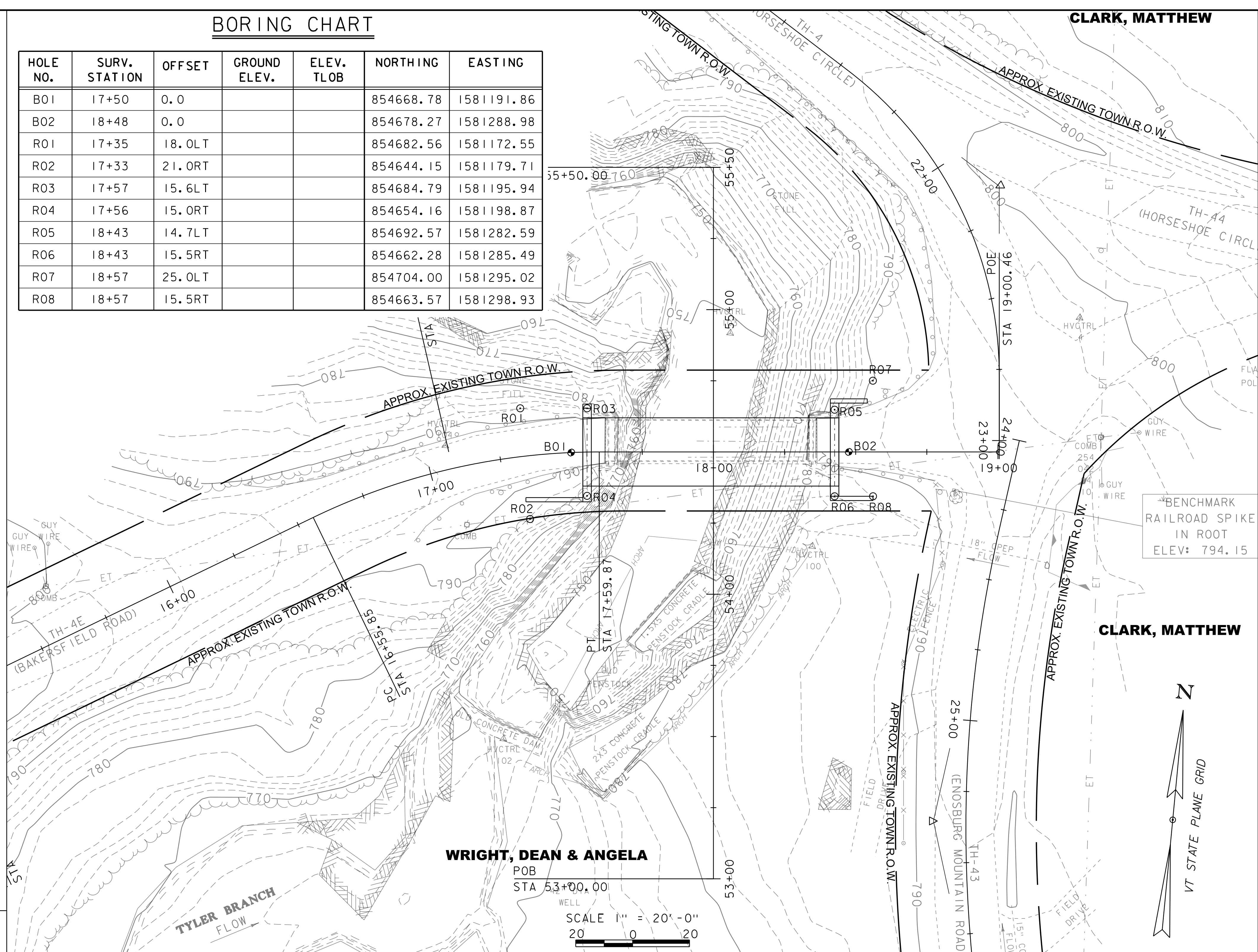

GENERAL NOTES

- The subsurface explorations shown herein were made between and by the Agency.
- Soil and rock classifications, properties and descriptions are based on engineering interpretation from available subsurface information by the Agency and may not necessarily reflect actual variations in subsurface conditions that may be encountered between individual boring or sample locations.
- Observed water levels and/or conditions indicated are as recorded at the time of exploration and may vary according to the prevailing rainfall, methods of exploration and other factors.
- Engineering judgment was exercised in preparing the subsurface information presented herein. Analysis and interpretation of subsurface data was performed and interpreted for Agency design and estimating purposes. Presentation of the information in the Contract is intended to provide the Contractor access to the same data available to the Agency. The subsurface information is presented in good faith and is not intended as a substitute for personal investigation, independent interpretation, independent analysis or judgment by the Contractor.
- Pictorial structure details shown on the boring plan layout or soils profile are for illustrative purposes only and may not accurately portray final contract details.
- Terminology used on boring logs to describe the hardness, degree of weathering, and spacing of fractures, joints and other discontinuities in the bedrock is defined in the AASHTO Manual on Subsurface Investigations, 1988.
- Northing and Easting coordinates are shown in Vermont State Plane Grid North American Datum 1983 in meters and survey feet.

DEFINITIONS (AASHTO)

- BEDROCK (LEDGE) - Rock in its native location of indefinite thickness.
- BOULDER - A rock fragment with an average dimension > 12 inches.
- COBBLE - Rock fragments with an average dimension between 3 and 12 inches.
- GRAVEL - Rounded particles of rock < 3" and > 0.0787" (#10 sieve).
- SAND - Particles of rock < 0.0787" (#10 sieve) and > 0.0029" (#200 sieve).
- SLT - Soil < 0.0029" (#200 sieve), non or slightly plastic and exhibits no strength when air-dried.
- CLAY - Fine grained soil, exhibits plasticity when moist and considerable strength when air-dried.
- VARVED - Alternate layers of silt and clay.
- HARDPAN - Extremely dense soil, cemented layer, not softened when wet.
- MUCK - Soft organic soil (containing > 10% organic material).
- MOISTURE CONTENT - Weight of water divided by dry weight of soil.
- FLOWING SAND - Granular soil so saturated (loose) that it flows into drill casing during extraction of wash rod.
- STRIKE - Angle from magnetic north to line of intersection of bed with a horizontal plane.
- DIP - Inclination of bed with a horizontal plane.

PROJECT NAME: ENOSBURG
 PROJECT NUMBER: BO 1448(45)
 FILE NAME: I9J224/s19J224borings.dgn
 PROJECT LEADER: R.YOUNG
 DESIGNED BY: D.PETERSON
 BORING INFORMATION SHEET

PLOT DATE: 06-JUL-2020
 DRAWN BY: D.D.BEARD
 CHECKED BY: J.LACROIX
 SHEET 7 OF 20

TH-4 EXISTING CURVE 1
 DELTA = 52°35'57"
 D = 42°26'29"
 R = 135.00'
 T = 66.72'
 L = 23.93'
 E = 15.49'

PROPOSED CURVE 2
 DELTA = 25°47'56"
 D = 24°48'12"
 R = 231.00'
 T = 52.90'
 L = 104.01'
 E = 5.98'

STA 18+00.00 =
 CHAN 54+50.00
 Δ = 90°00'00" LT

EXISTING CURVE 1
 DELTA = 50°57'51"
 D = 21°37'16"
 R = 265.00'
 T = 126.30'
 L = 235.72'
 E = 28.56'

TH-43 EXISTING CURVE 1
 DELTA = 24°52'31"
 D = 12°03'44"
 R = 475.00'
 T = 104.76'
 L = 206.22'
 E = 11.42'

EXISTING BRIDGE INFORMATION
 BUILT 1918, REBUILT 1975
 74' SINGLE SPAN ROLLED BEAM
 CONCRETE CAST IN PLACE DECK

UTILITY RELOCATION LAYOUT

SCALE 1" = 20'-0"
 20 0 20

PROJECT NAME:	ENOSBURG	FILE NAME:	19J224/s19J224border.dgn	PLOT DATE:	06-JUL-2020
PROJECT NUMBER:	BO 1448(45)	PROJECT LEADER:	R.YOUNG	DRAWN BY:	D.D.BEARD
		DESIGNED BY:	D.PETERSON	CHECKED BY:	J.LACROIX
		UTILITY RELOCATION LAYOUT SHEET		SHEET	8 OF 20

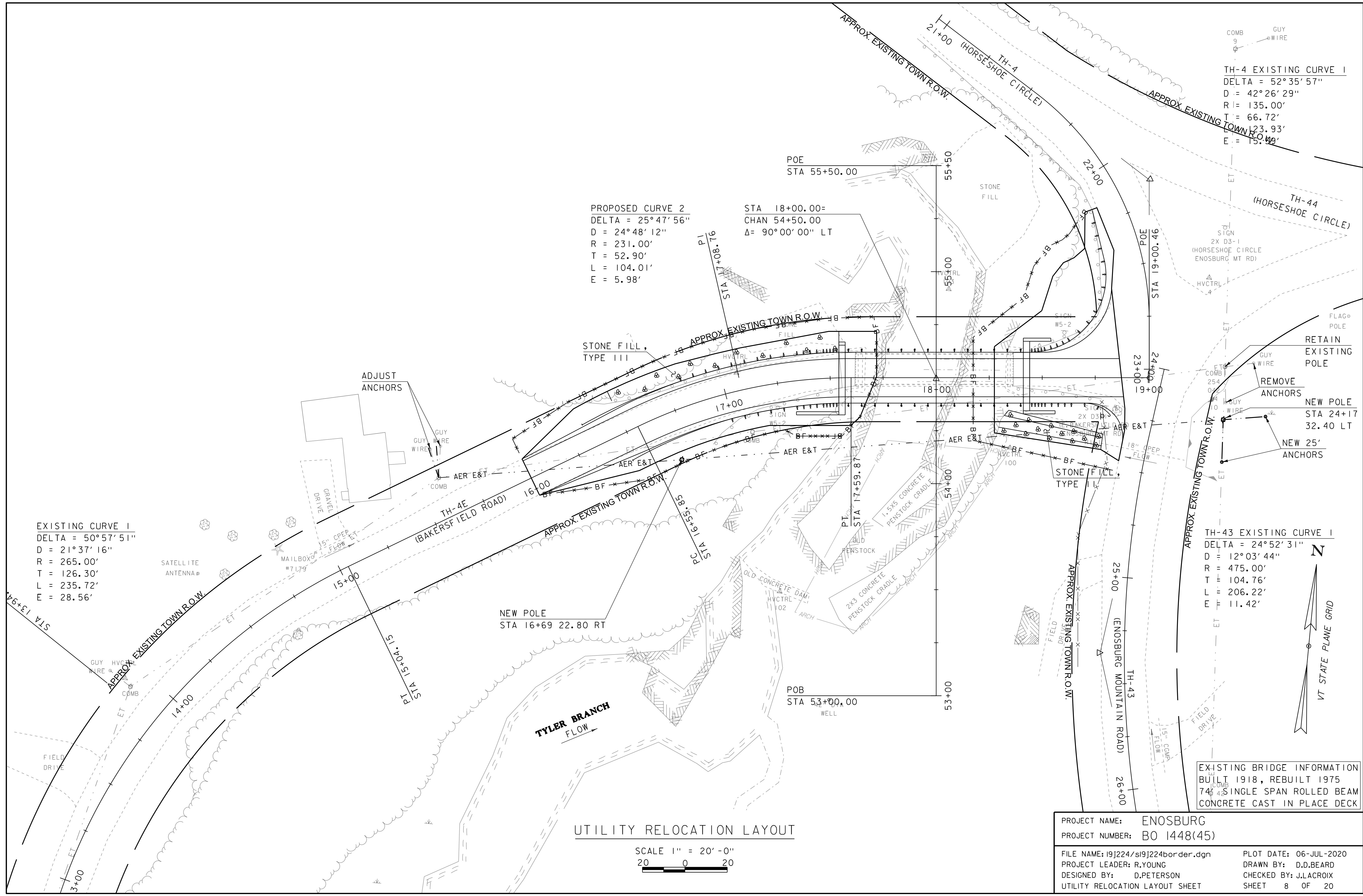

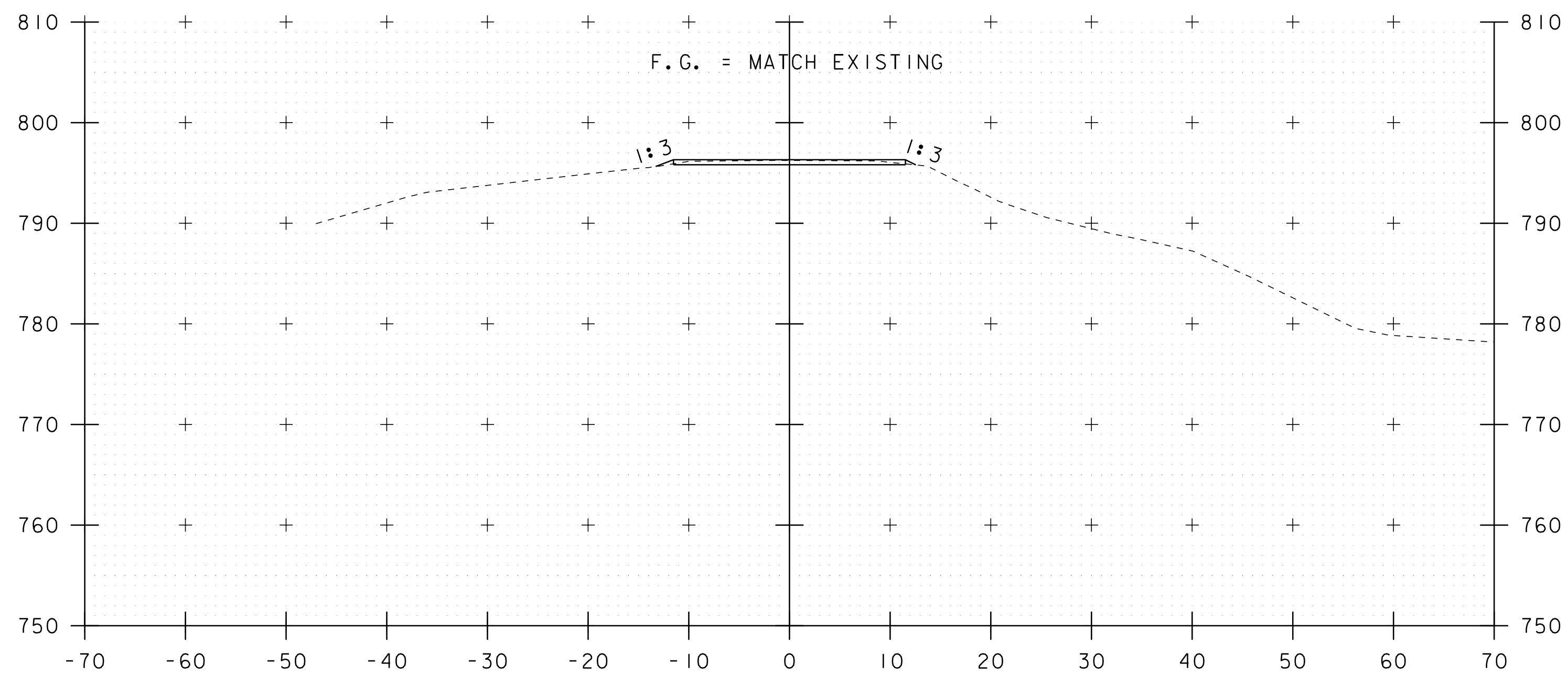

STA 16+00.00
 BEGIN APPROACH
 BEGIN GEOTEXTILE FOR ROADWAY SEPARATOR

16+00

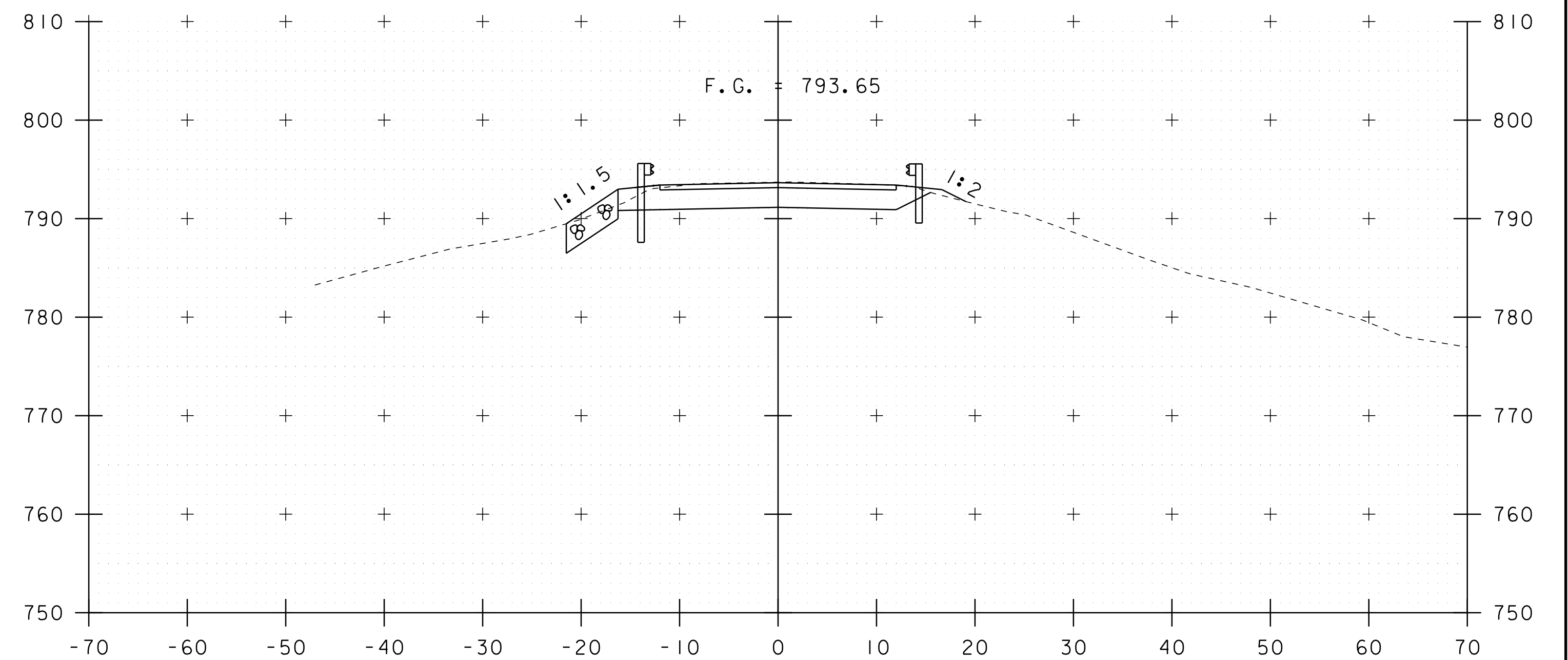

STA 16+50.00
 BEGIN PROJECT
 BEGIN STONE FILL, TYPE III
 BEGIN GEOTEXTILE UNDER STONE FILL

16+50

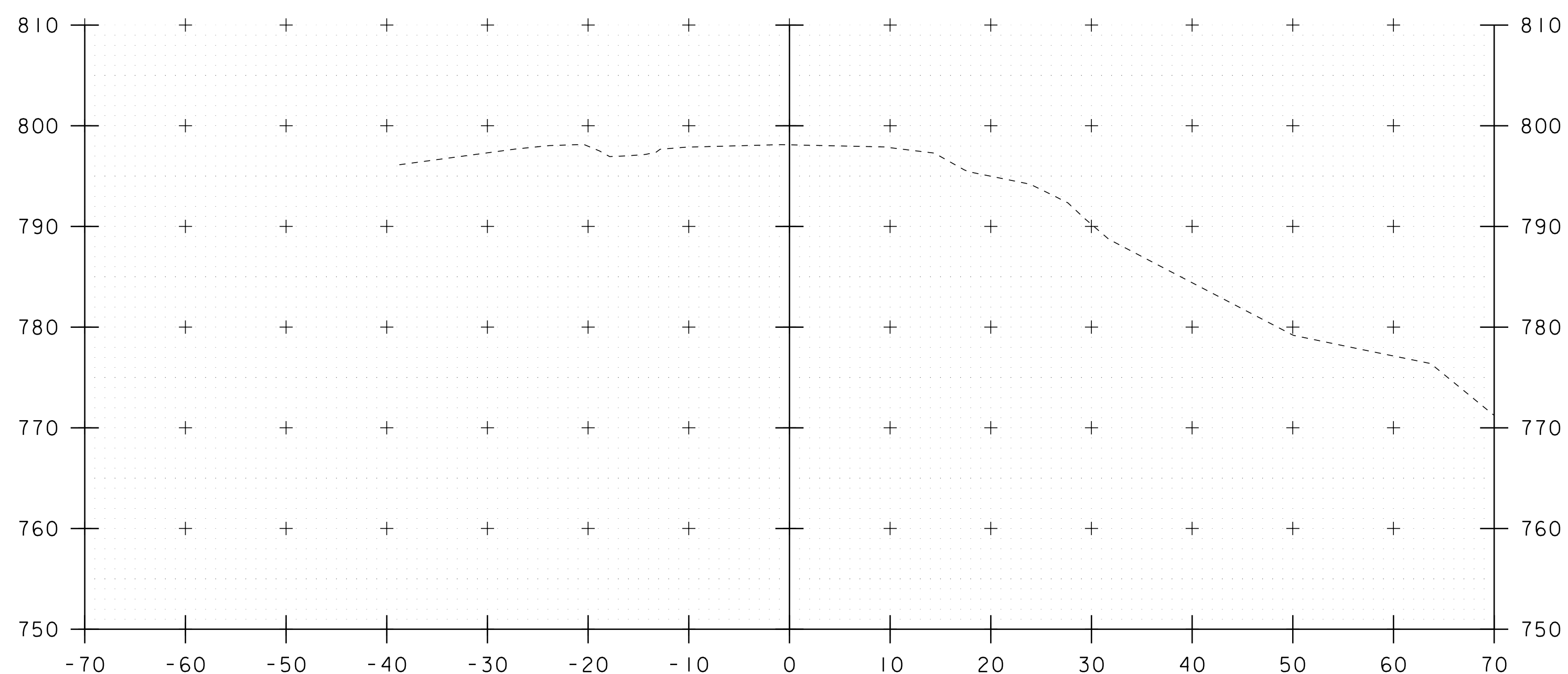

15+75

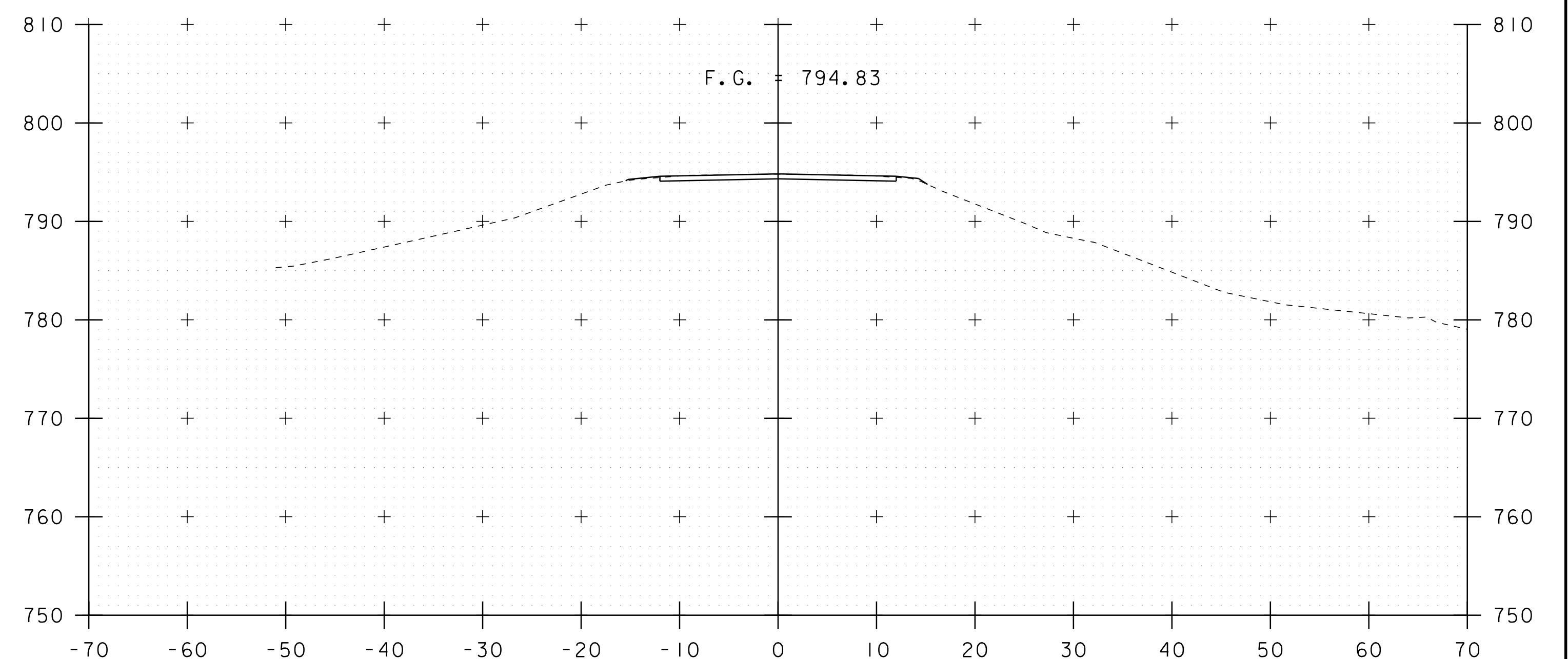

16+25

STA. 15+75 TO STA. 16+50

PROJECT NAME: ENOSBURG	
PROJECT NUMBER: BO 1448(45)	
FILE NAME: I9J224/s19J224xs.dgn	PLOT DATE: 06-JUL-2020
PROJECT LEADER: R.YOUNG	DRAWN BY: D.D.BEARD
DESIGNED BY: D.PETERSON	CHECKED BY: J.LACROIX
ROADWAY CROSS SECTIONS I	SHEET 9 OF 20

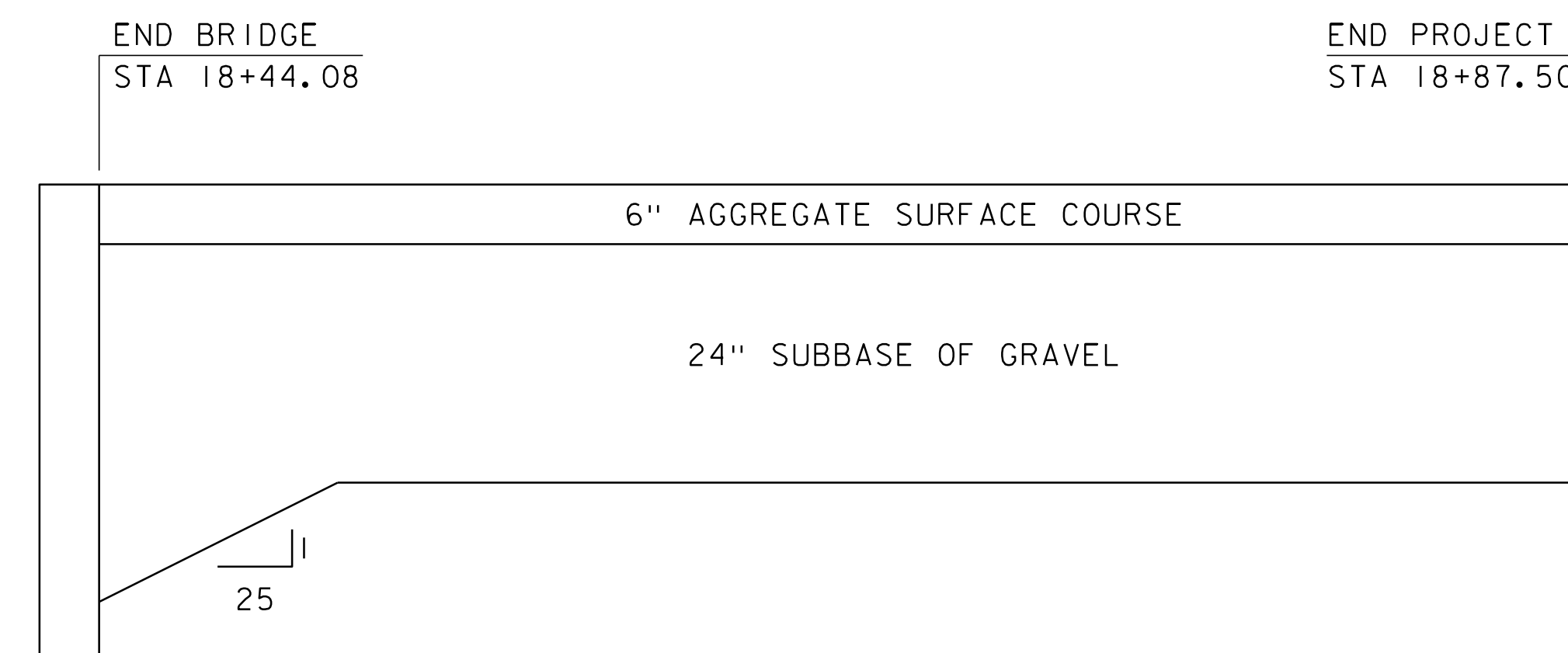
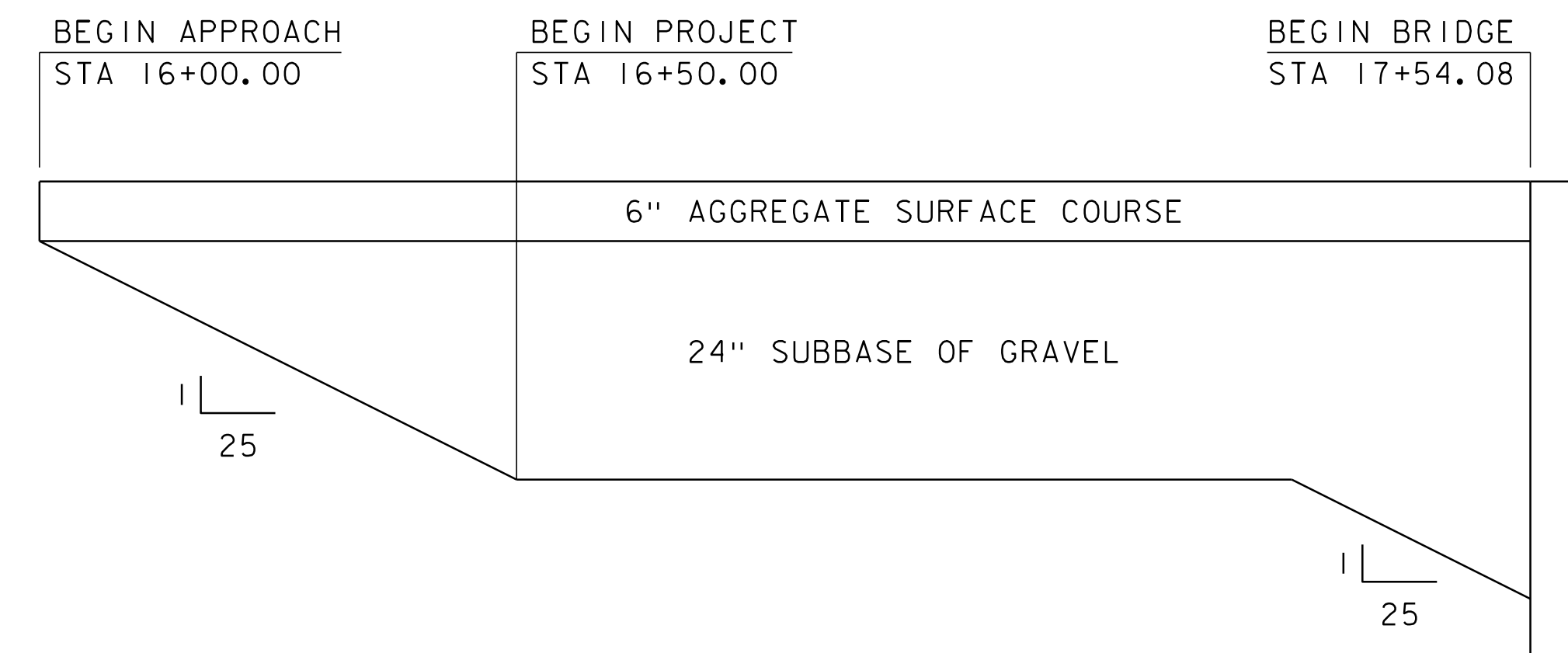
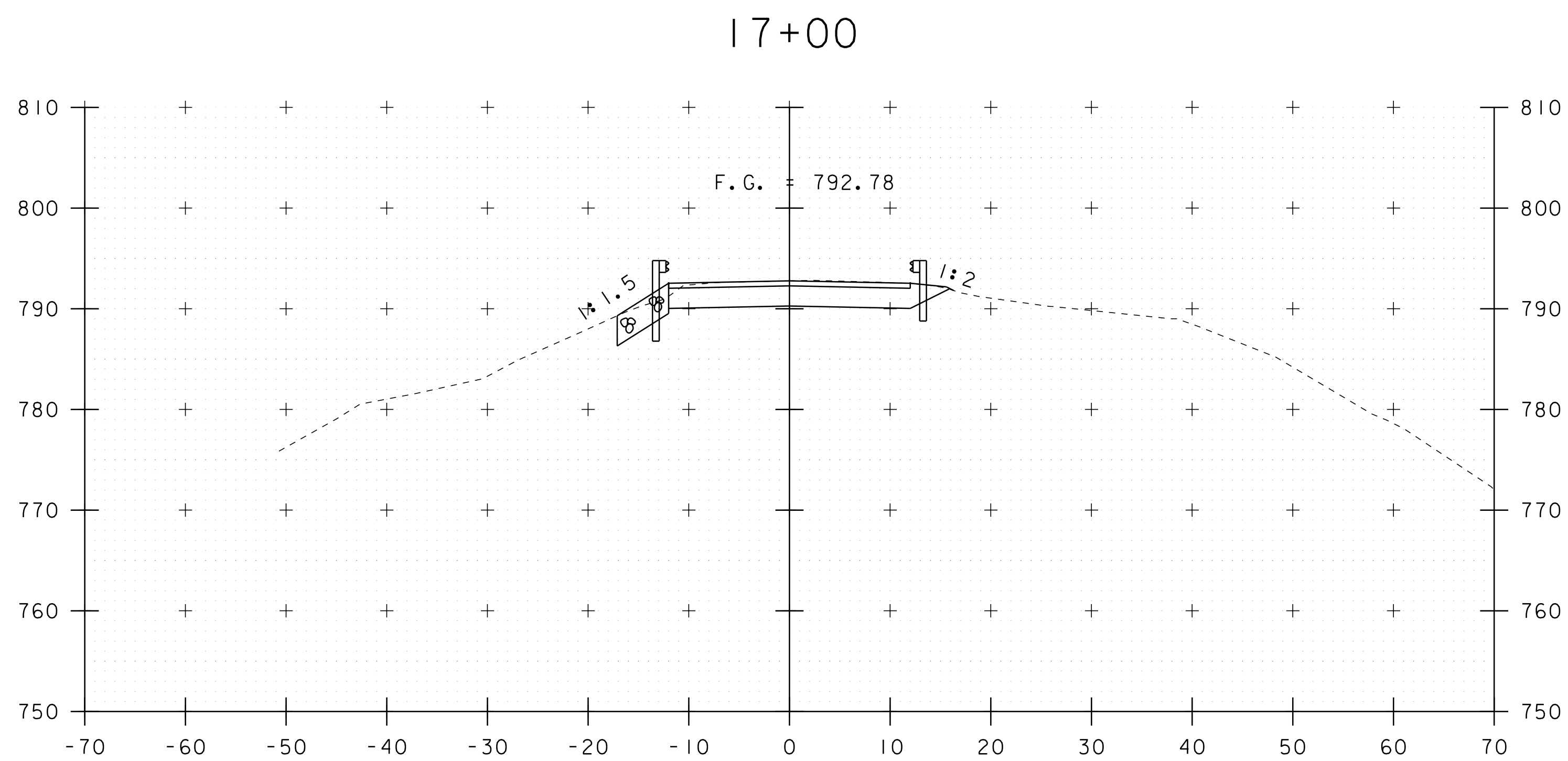
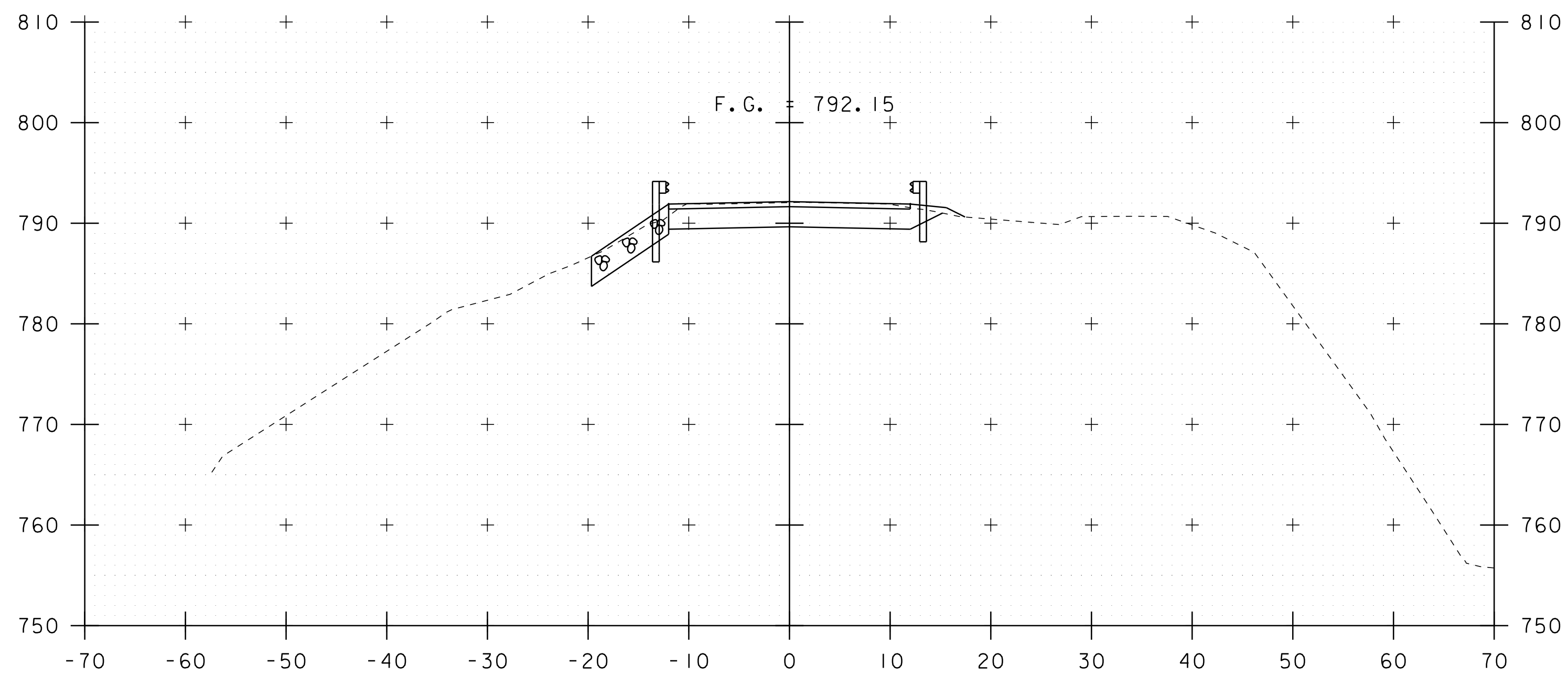

STA. 16+75 TO STA. 17+00

PROJECT NAME: ENOSBURG
PROJECT NUMBER: BO 1448(45)

FILE NAME: I9J224/s19J224xs.dgn
PROJECT LEADER: R.YOUNG
DESIGNED BY: D.PETERSON
ROADWAY CROSS SECTIONS 2

PLOT DATE: 06-JUL-2020
DRAWN BY: D.D.BEARD
CHECKED BY: J.LACROIX
SHEET 10 OF 20

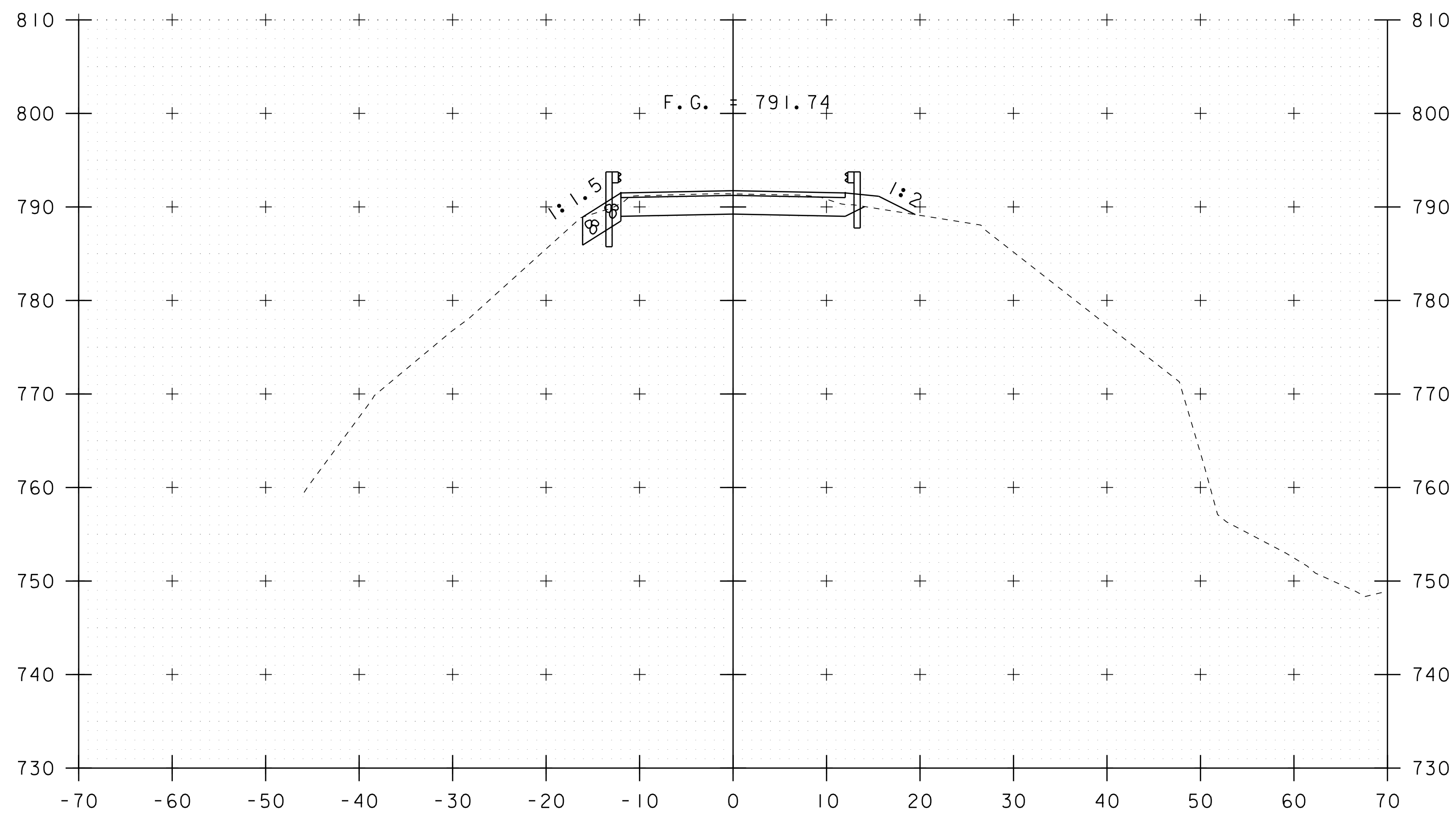

17+25

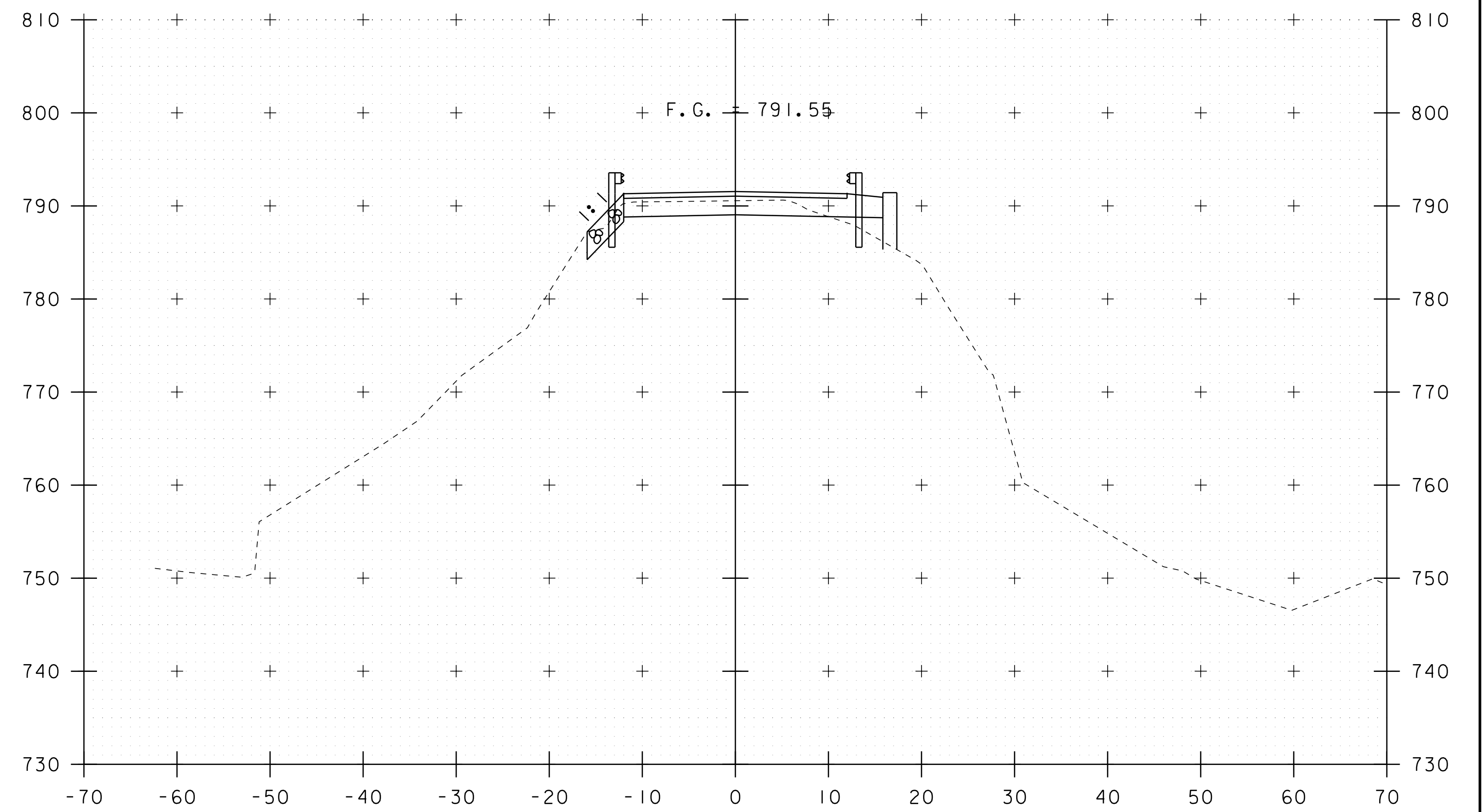

STA 17+54.083
 BEGIN BRIDGE
 END GEOTEXTILE FOR ROADWAY SEPARATOR

17+50

STA. 17+25 TO STA. 17+50

PROJECT NAME: ENOSBURG	
PROJECT NUMBER: BO 1448(45)	
FILE NAME: I9J224/s19J224xs.dgn	PLOT DATE: 06-JUL-2020
PROJECT LEADER: R.YOUNG	DRAWN BY: D.D.BEARD
DESIGNED BY: D.PETERSON	CHECKED BY: J.LACROIX
ROADWAY CROSS SECTIONS 3	SHEET II OF 20

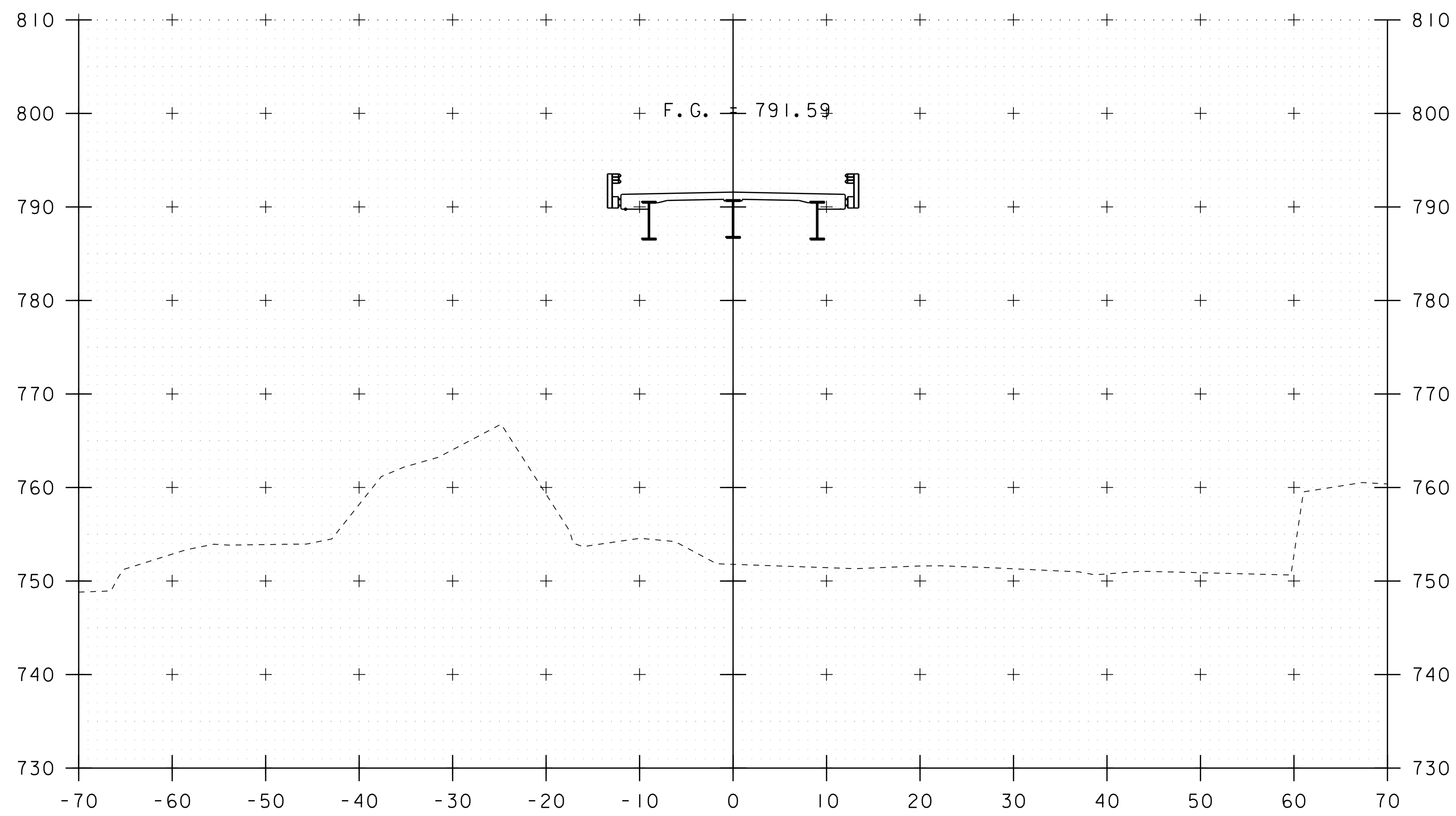

17+75

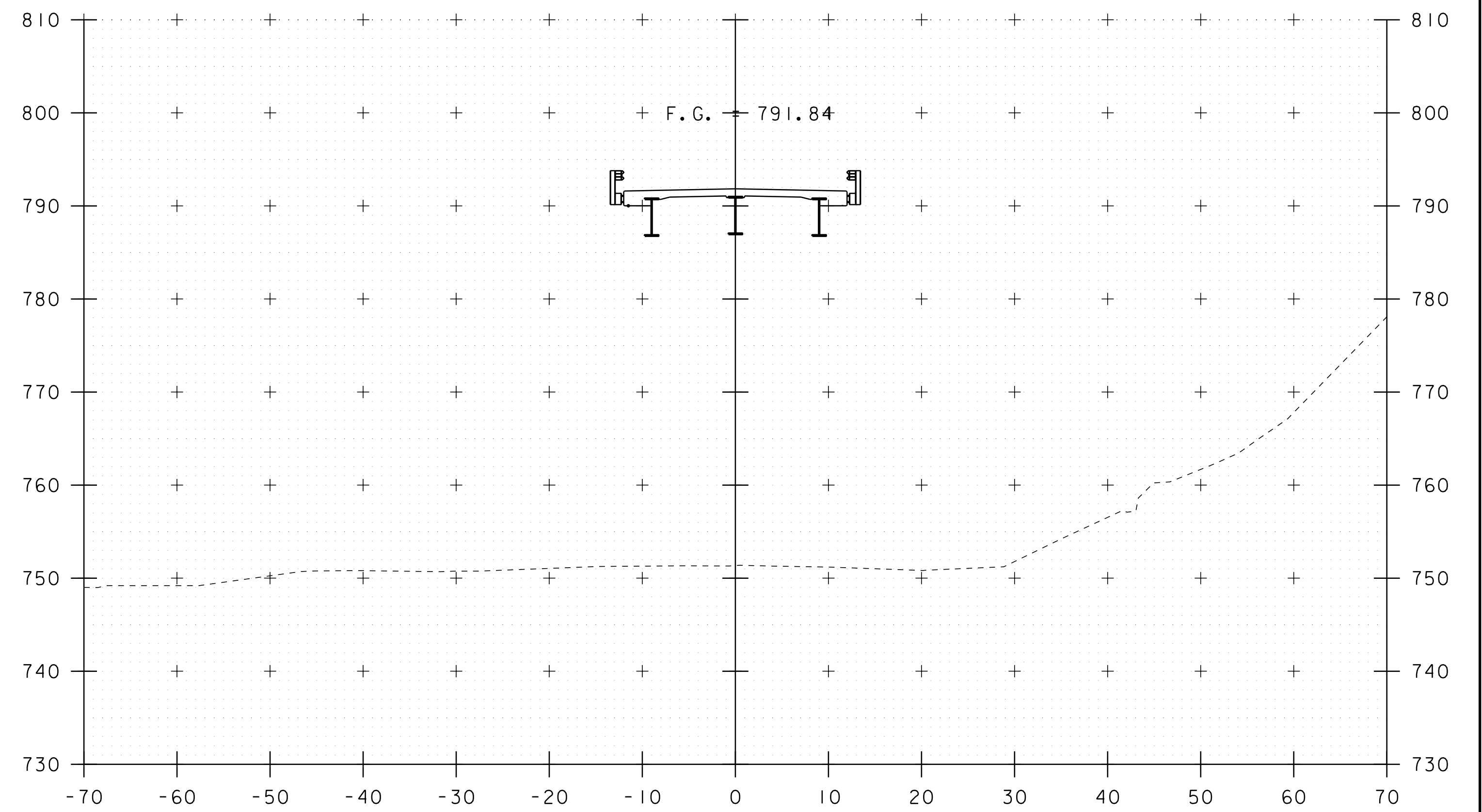

18+00

STA. 17+75 TO STA. 18+00

PROJECT NAME: ENOSBURG	
PROJECT NUMBER: BO 1448(45)	
FILE NAME: I9J224/s19J224xs.dgn	PLOT DATE: 06-JUL-2020
PROJECT LEADER: R.YOUNG	DRAWN BY: D.D.BEARD
DESIGNED BY: D.PETERSON	CHECKED BY: J.LACROIX
ROADWAY CROSS SECTIONS 4	SHEET 12 OF 20

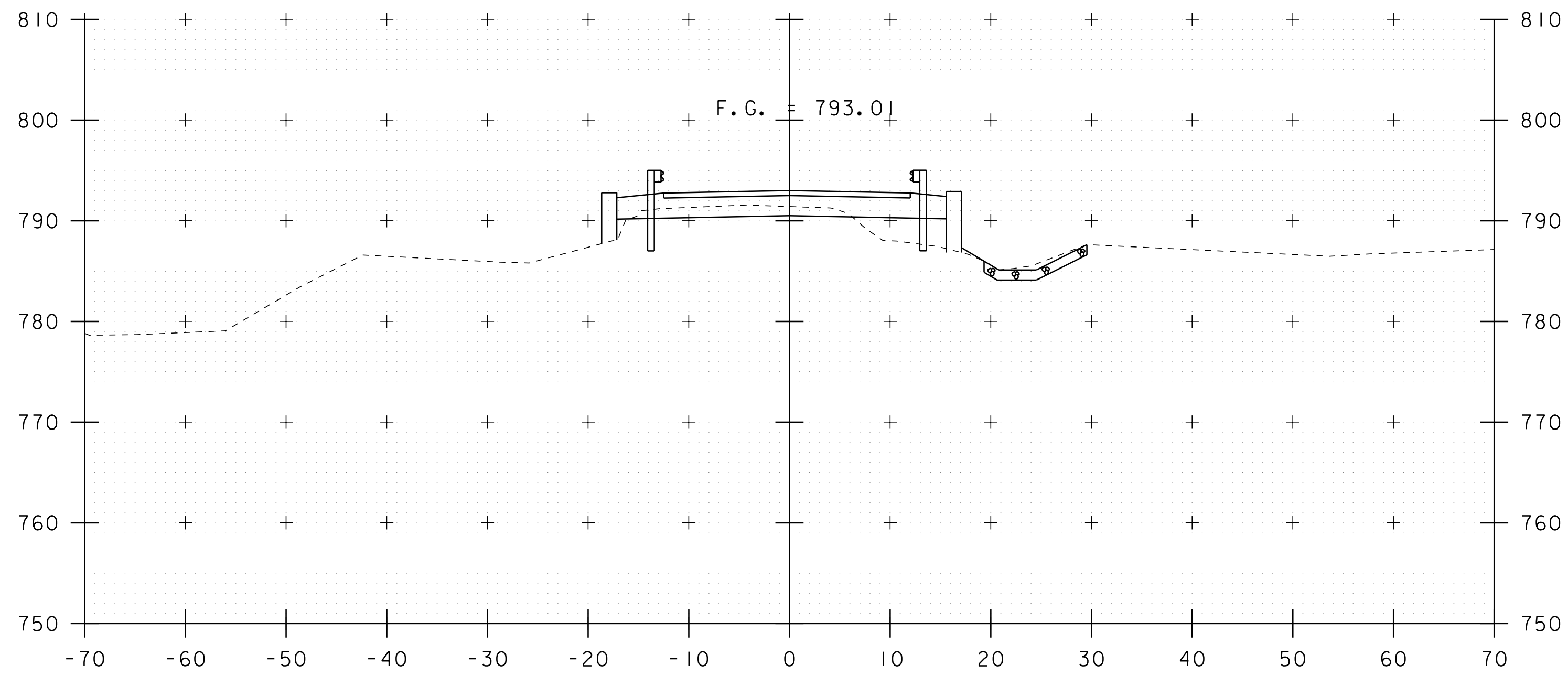

18+50

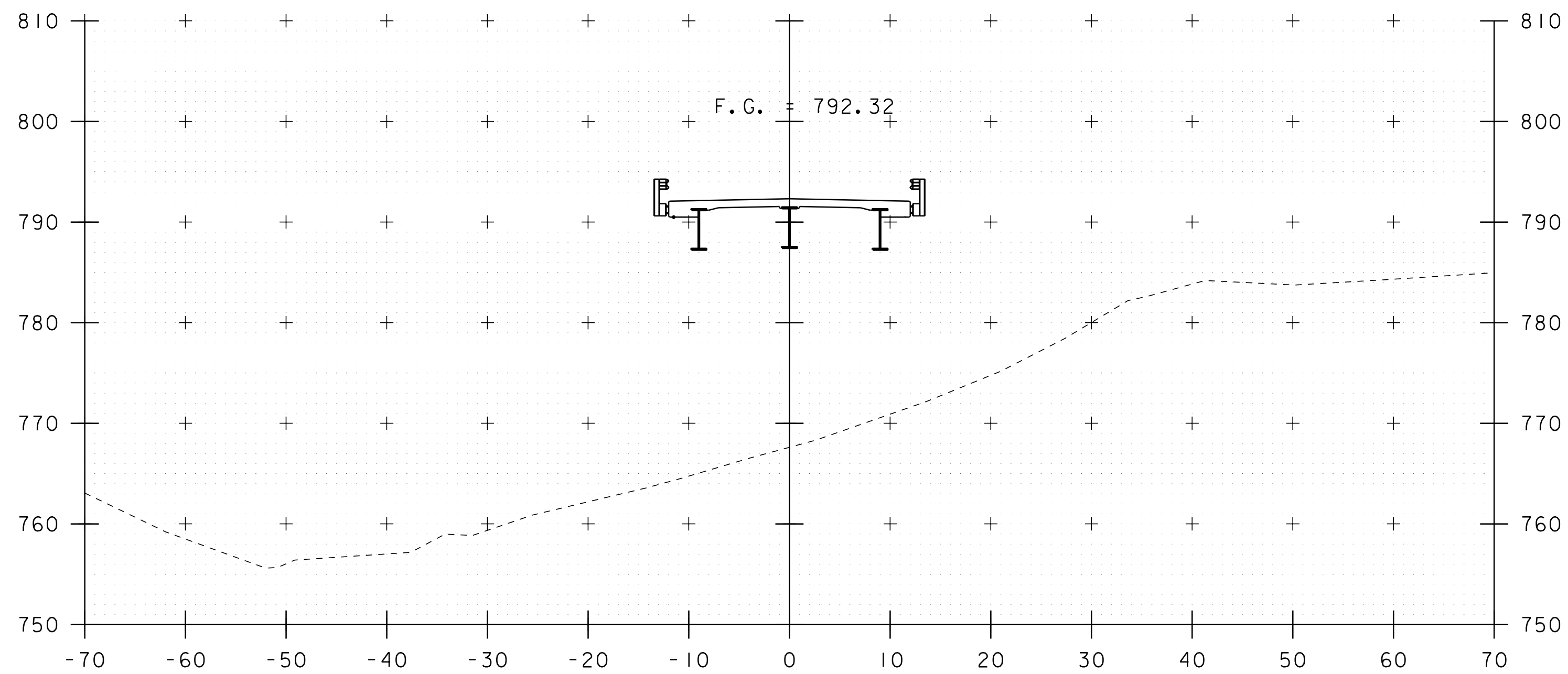

18+25

STA 18+28.70
 BEGIN STONE FILL, TYPE II
 BEGIN GEOTEXTILE UNDER STONE FILL
 STA 18+44.083
 END BRIDGE
 BEGIN GEOTEXTILE FOR ROADWAY SEPARATOR

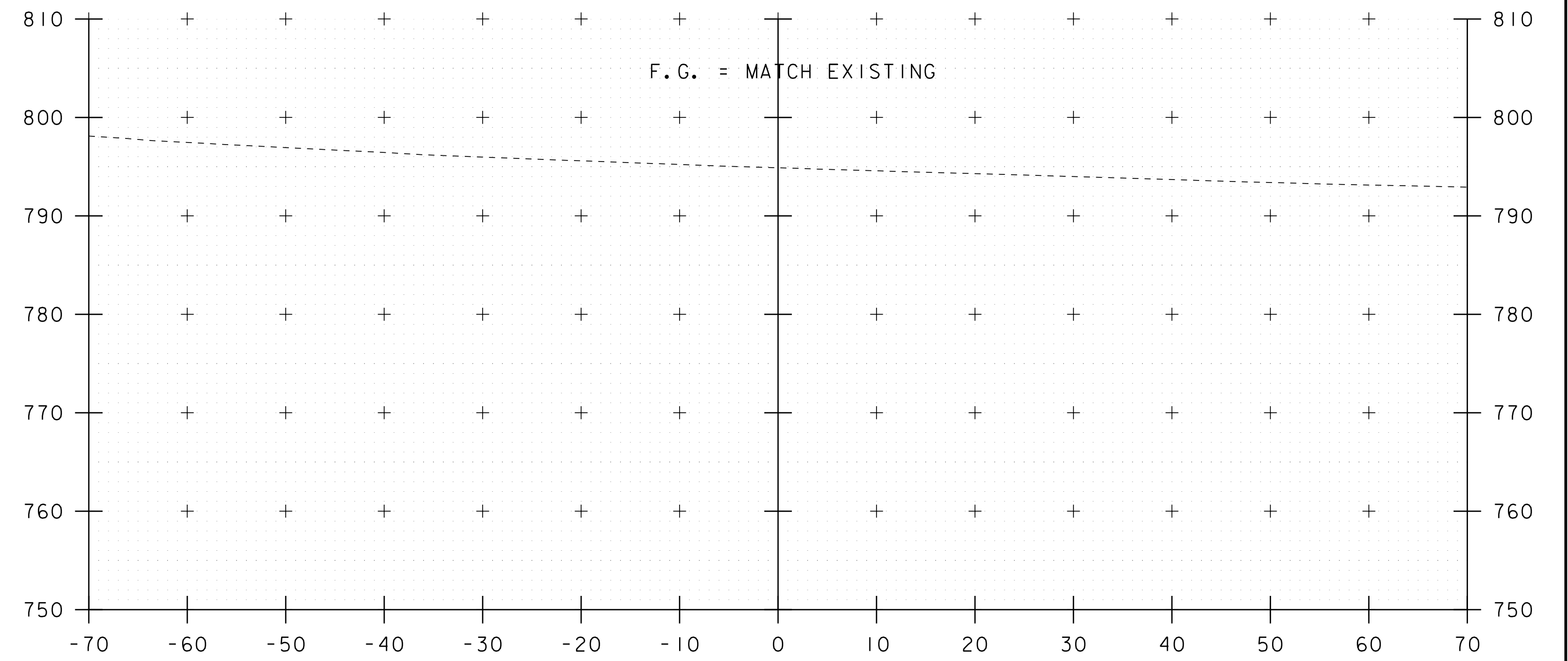

19+00

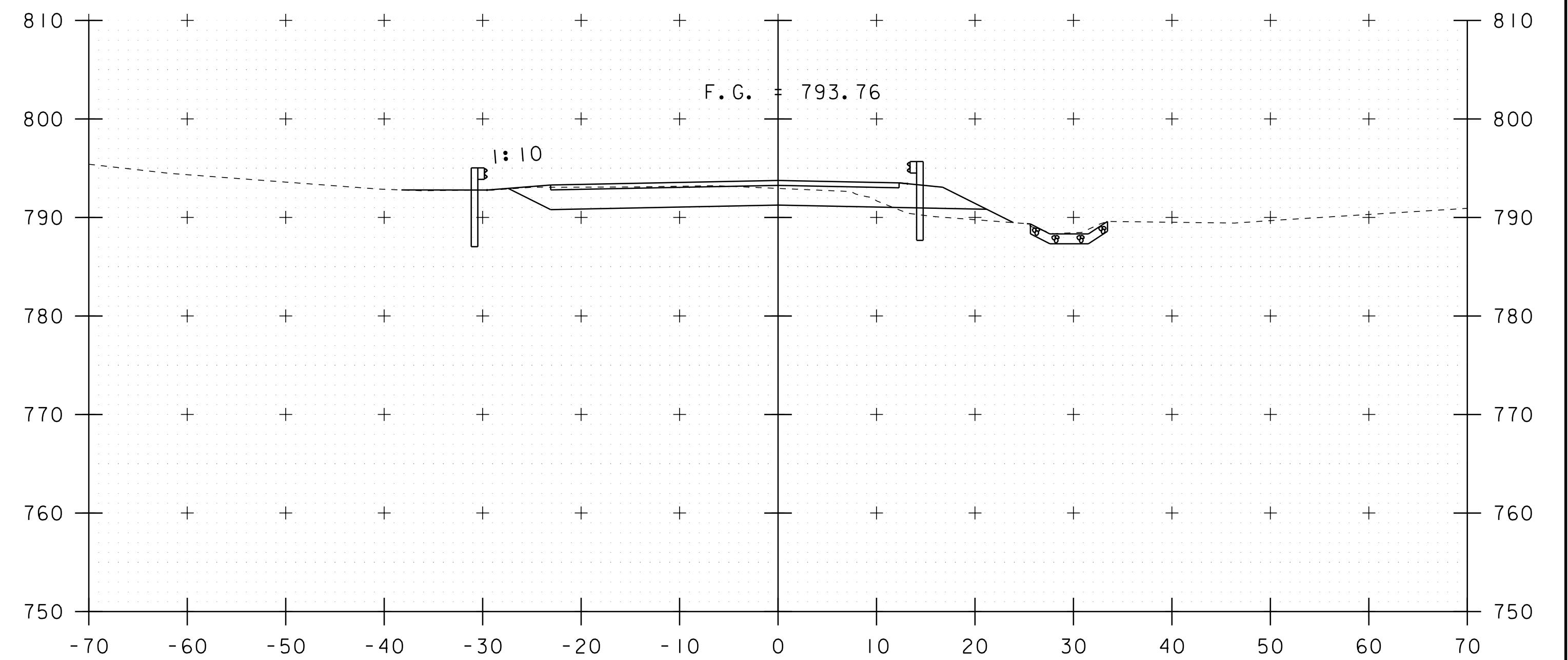

18+75

STA 18+78.60
 END STONE FILL, TYPE II
 END GEOTEXTILE UNDER STONE FILL
 STA 18+87.50
 END PROJECT
 END GEOTEXTILE FOR ROADWAY SEPARATOR

STA. 18+25 TO STA. 19+00

PROJECT NAME: ENOSBURG	
PROJECT NUMBER: BO 1448(45)	
FILE NAME: I9J224/s19J224xs.dgn	PLOT DATE: 06-JUL-2020
PROJECT LEADER: R.YOUNG	DRAWN BY: D.D.BEARD
DESIGNED BY: D.PETERSON	CHECKED BY: J.LACROIX
ROADWAY CROSS SECTIONS 5	SHEET 13 OF 20

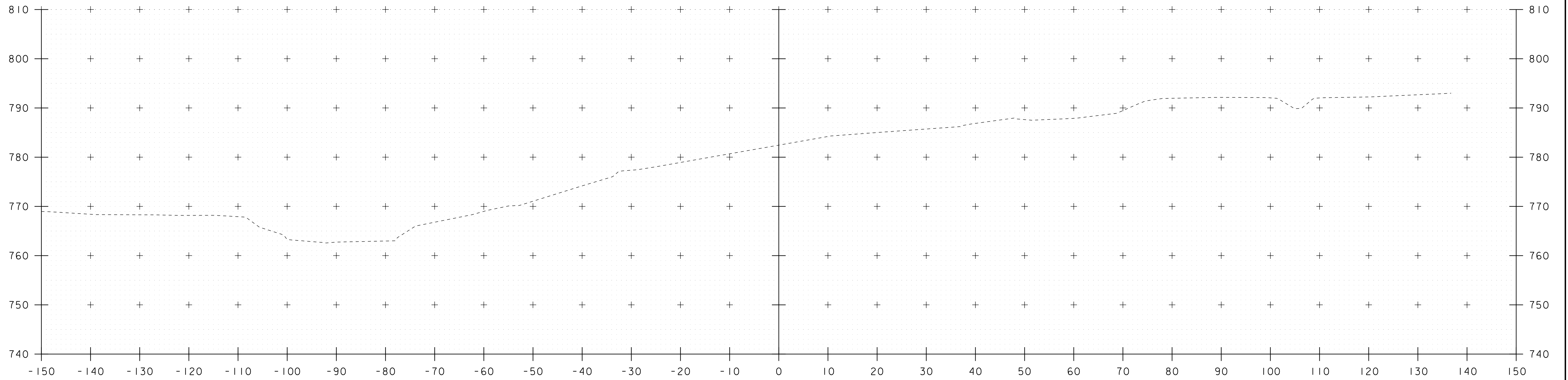

53+25

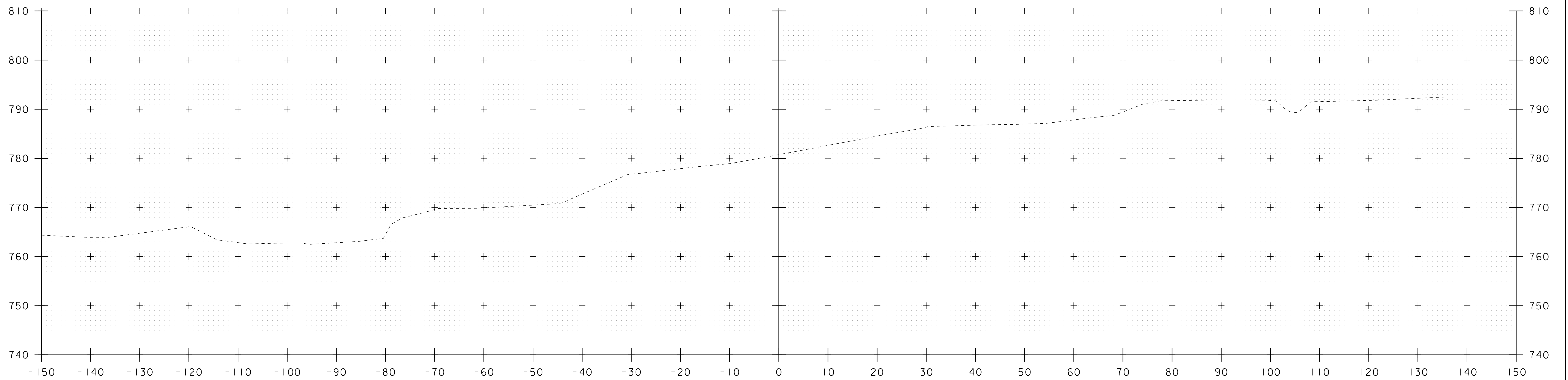

53+00

STA. 53+00 TO STA. 53+25

PROJECT NAME: ENOSBURG	
PROJECT NUMBER: BO 1448(45)	
FILE NAME: I9J224/s19J224xs.dgn	PLOT DATE: 06-JUL-2020
PROJECT LEADER: R.YOUNG	DRAWN BY: D.D.BEARD
DESIGNED BY: D.PETERSON	CHECKED BY: J.LACROIX
CHANNEL CROSS SECTIONS 1	SHEET 14 OF 20

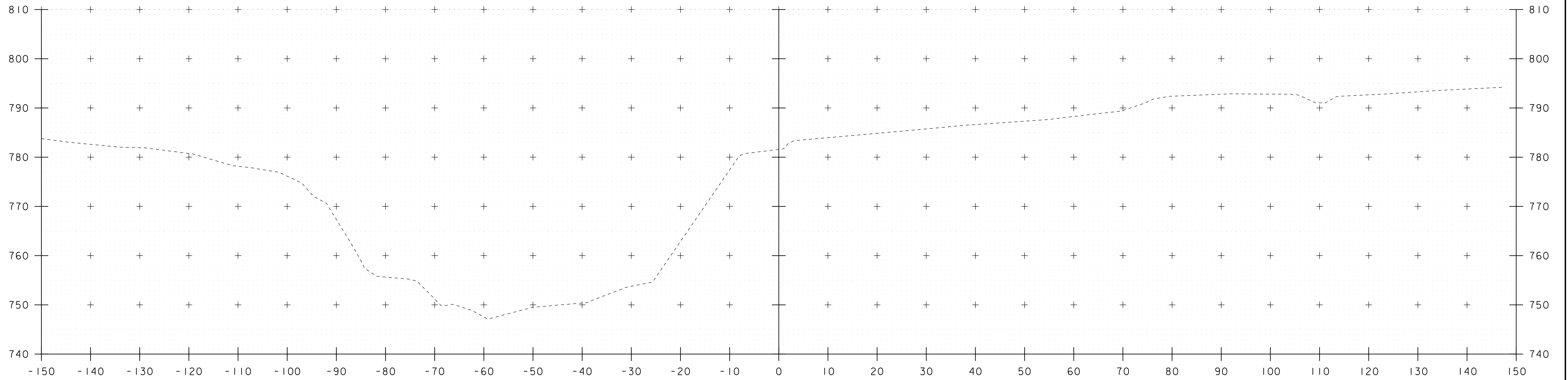

53+75

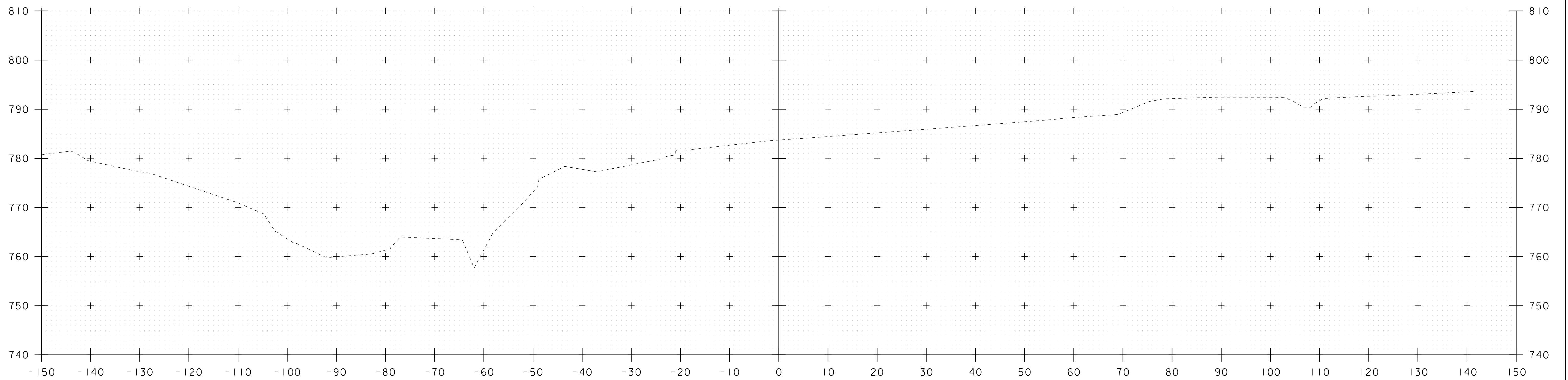

53+50

STA. 53+50 TO STA. 53+75

PROJECT NAME: ENOSBURG	
PROJECT NUMBER: BO 1448(45)	
FILE NAME: I9J224/s19J224xs.dgn	PLOT DATE: 06-JUL-2020
PROJECT LEADER: R.YOUNG	DRAWN BY: D.D.BEARD
DESIGNED BY: D.PETERSON	CHECKED BY: J.LACROIX
CHANNEL CROSS SECTIONS 2	SHEET 15 OF 20

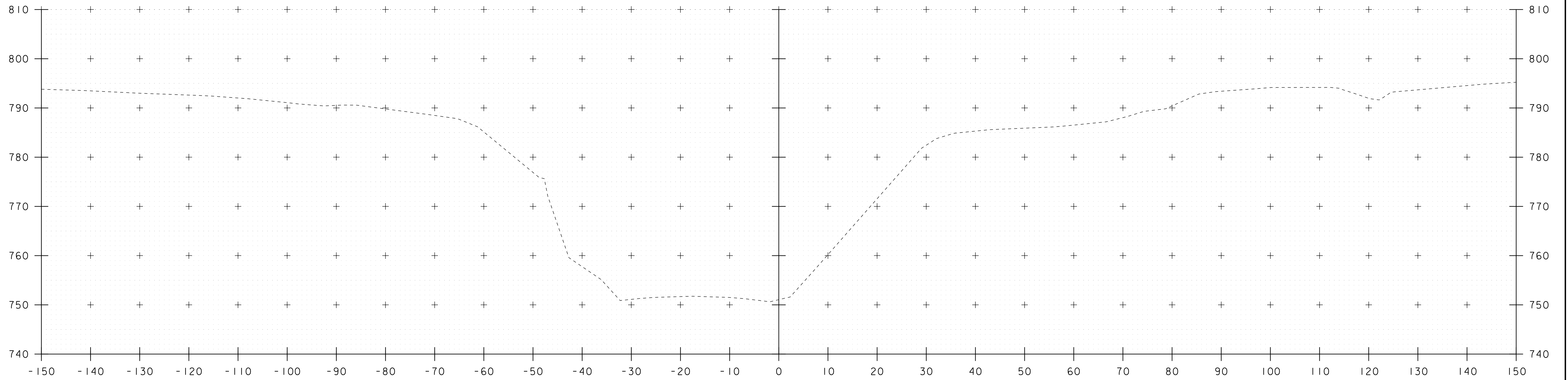

54+25

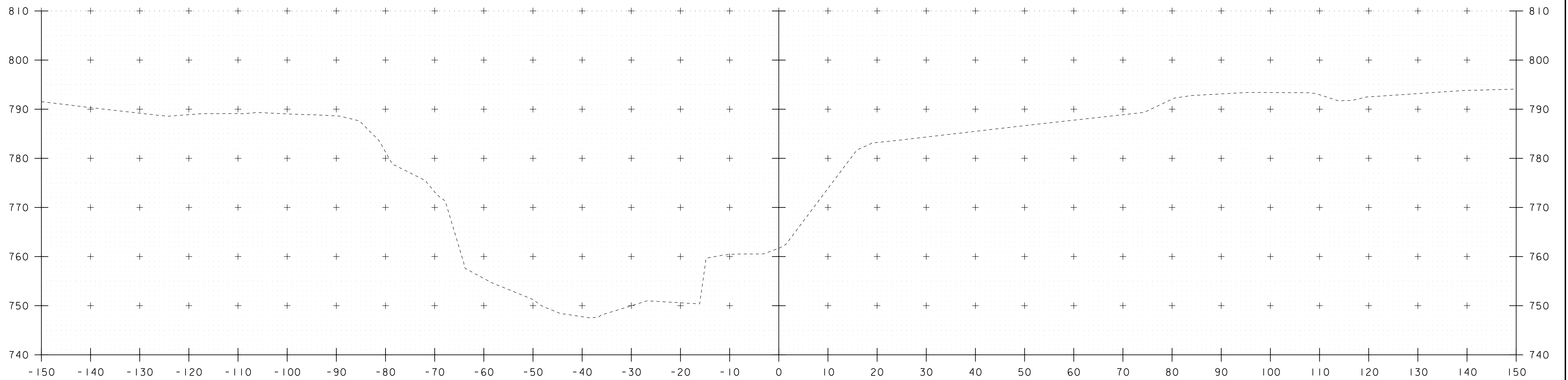

54+00

STA. 54+00 TO STA. 54+25

PROJECT NAME: ENOSBURG	
PROJECT NUMBER: BO 1448(45)	
FILE NAME: I9J224/s19J224xs.dgn	PLOT DATE: 06-JUL-2020
PROJECT LEADER: R.YOUNG	DRAWN BY: D.D.BEARD
DESIGNED BY: D.PETERSON	CHECKED BY: J.LACROIX
CHANNEL CROSS SECTIONS 3	SHEET 16 OF 20

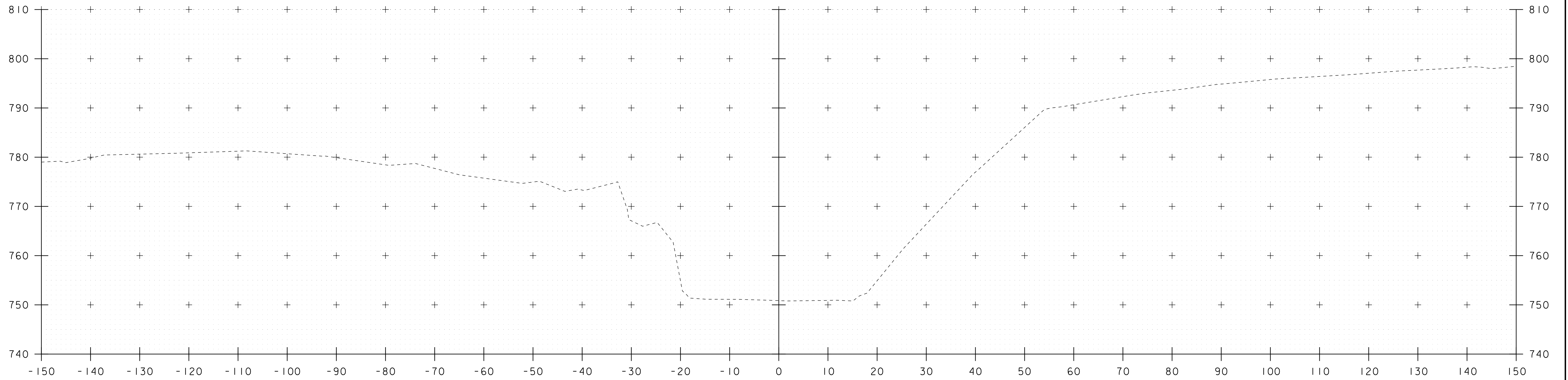

54+75

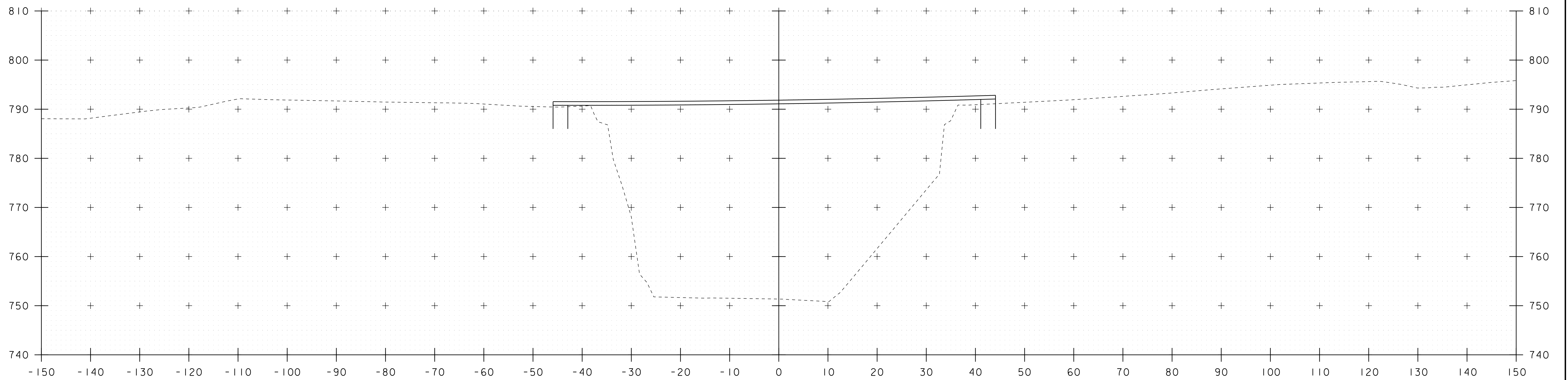

54+50

STA. 54+50 TO STA. 54+75

PROJECT NAME: ENOSBURG	PLOT DATE: 06-JUL-2020
PROJECT NUMBER: BO 1448(45)	DRAWN BY: D.D.BEARD
FILE NAME: I9J224/s19J224xs.dgn	DESIGNED BY: D.PETERSON
PROJECT LEADER: R.YOUNG	CHECKED BY: J.LACROIX
CHANNEL CROSS SECTIONS 4	SHEET 17 OF 20

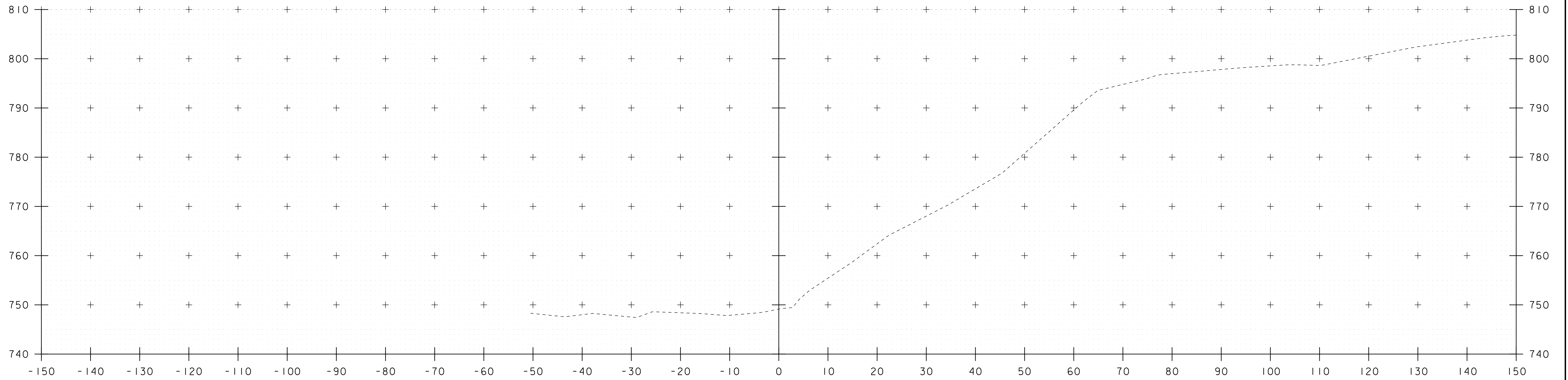

55+25

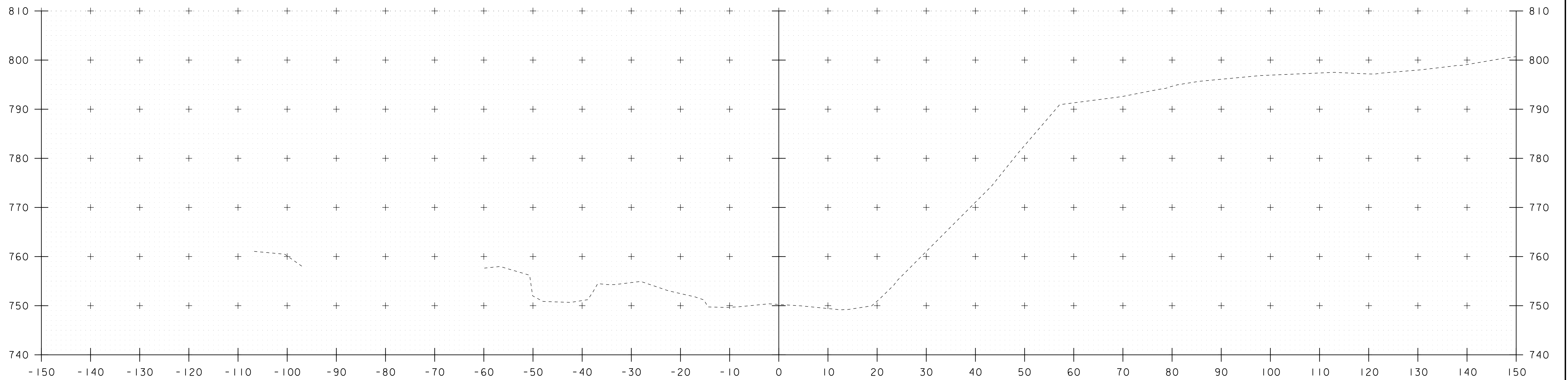

55+00

STA. 55+00 TO STA. 55+25

PROJECT NAME: ENOSBURG	PLOT DATE: 06-JUL-2020
PROJECT NUMBER: BO 1448(45)	DRAWN BY: D.D.BEARD
FILE NAME: I9J224/s19J224xs.dgn	CHECKED BY: J.LACROIX
PROJECT LEADER: R.YOUNG	SHEET 18 OF 20
DESIGNED BY: D.PETERSON	
CHANNEL CROSS SECTIONS 5	

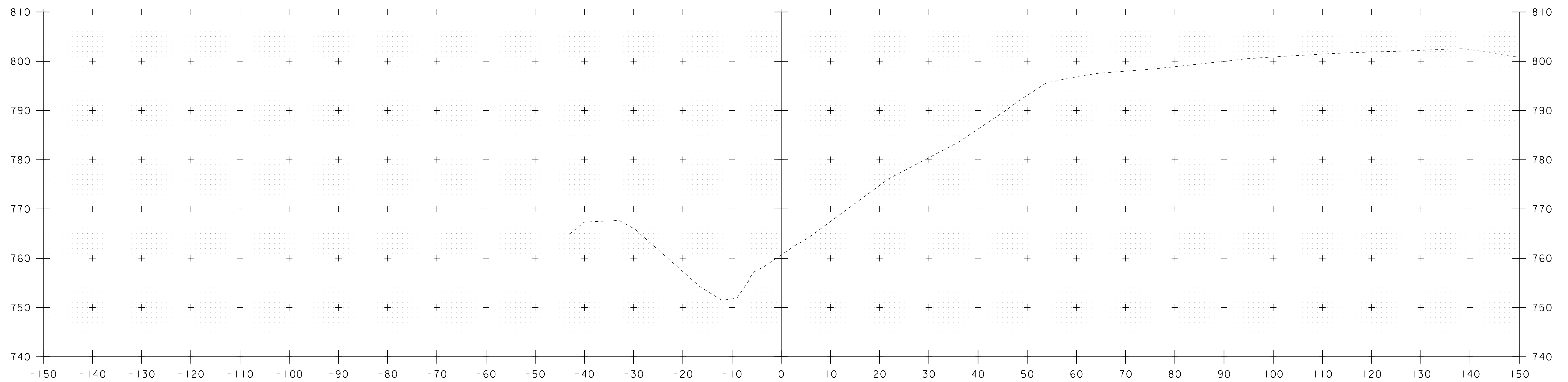

55+50

STA. 55+50 TO STA. 55+50

PROJECT NAME: ENOSBURG	
PROJECT NUMBER: BO 1448(45)	
FILE NAME: I9J224/s19J224xs.dgn	PLOT DATE: 06-JUL-2020
PROJECT LEADER: R.YOUNG	DRAWN BY: D.D.BEARD
DESIGNED BY: D.PETERSON	CHECKED BY: J.LACROIX
CHANNEL CROSS SECTIONS 6	SHEET 19 OF 20

CLARK, MATTHEW

TH-4 EXISTING CURVE 1
DELTA = 52°35'57"
D = 42°26'29"
R = 135.00'
T = 66.72'
L = 23.93'
E = 15.49'

WRIGHT, DEAN & ANGELA

EXISTING CURVE 2
DELTA = 25°47'56"
D = 24°48'12"
R = 231.00'
T = 52.90'
L = 104.01'
E = 5.98'

STA 18+00.00=
CHAN 54+50.00
Δ = 90°00'00" LT

CLARK, MATTHEW

TH-43 EXISTING CURVE 1
DELTA = 24°52'31"
D = 12°03'44"
R = 475.00'
T = 104.76'
L = 206.22'
E = 11.42'

EXISTING CURVE 1
DELTA = 50°57'51"
D = 21°37'16"
R = 265.00'
T = 126.30'
L = 235.72'
E = 28.56'

BENCHMARK
RAILROAD SPIKE
IN ROOT
ELEV: 794.15

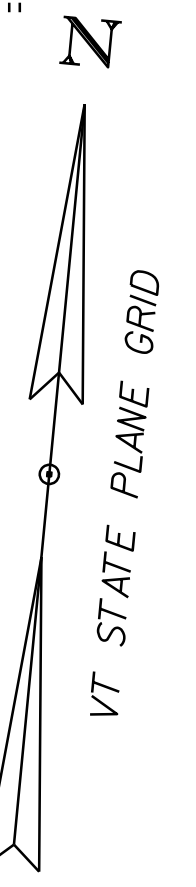

EXISTING BRIDGE INFORMATION
BUILT 1918, REBUILT 1975
74' SINGLE SPAN ROLLED BEAM
CONCRETE CAST IN PLACE DECK

EXISTING CONDITIONS

SCALE 1" = 20'-0"
20 0 20

PROJECT NAME: ENOSBURG
PROJECT NUMBER: BO 1448(45)

FILE NAME: I9J224/s19J224border.dgn
PROJECT LEADER: R.YOUNG
DESIGNED BY: D.PETERSON
EXISTING CONDITIONS

PLOT DATE: 06-JUL-2020
DRAWN BY: D.D.BEARD
CHECKED BY: J.LACROIX
SHEET 20 OF 20

